

**TOSVERT VF-AS1/PS1****CC-Link** Option Instruction Manual**CCL001Z1****NOTICE**

1. Make sure that this instruction manual is delivered to the end user of the CC-Link option for the VF-AS1/PS1.
2. Read this manual before installing or operating the CC-Link option unit, and store it in a safe place for reference.
3. All information contained in this manual is subject to change without notice. Please confirm the latest information on our web site "[www.inverter.co.jp](http://www.inverter.co.jp)".



\*E6581476REV02\*



## Safety precautions

On the inverter and in its instruction manual, important information is contained for preventing injuries to users and damages to assets and for proper use of the device.

Read the instruction manual attached to the inverter along with this instruction manual for completely understand the safety precautions, the symbols and indications shown below.

Please adhere to the contents of these manuals at all times.





### Explanation of markings

Marking	Meaning of marking
 Danger	Indicates that errors in operation may lead to death or serious injury.
 Warning	Indicates that errors in operation may lead to injury (*1) to people or that these errors may cause damage to physical property. (*2)





(\*1) Such things as injury, burns or shock that will not require hospitalization or long periods of outpatient treatment.

(\*2) Physical property damage refers to wide-ranging damage to assets and materials.



### Meanings of symbols

Marking	Meaning of marking
	Indicates prohibition (Do not do it). What is prohibited will be described in or near the symbol in either text or picture form.
	Indicates something mandatory (must be done). What is mandatory will be described in or near the symbol in either text or picture form.
	Indicates danger. What is dangerous will be described in or near the symbol in either text or picture form.
	Indicates warning. What the warning should be applied to will be described in or near the symbol in either text or picture form.



■ Handling in general

 <b>Danger</b>	
 Disassembly prohibited	<ul style="list-style-type: none"> <li>▼ Never disassemble, modify or repair the product. Disassembling the product may cause electric shocks, fire or injuries. For repairs, call your sales/repair agency.</li> </ul>
 Prohibited	<ul style="list-style-type: none"> <li>▼ Do not attach this option to any inverter other than the VF-AS1/PS1. It may lead to electric shocks or fire.</li> <li>▼ When the inverter is energized, never detach the this option from the VF-AS1/PS1. It may lead to electric shocks.</li> <li>▼ Do not place or insert any kind of object into this option. (electrical wire cuttings, rods, wires) It may lead to electric shocks or fire.</li> <li>▼ Do not splash water over the product, and do not wipe the body with a wet cloth. It may lead to electric shocks or fire.</li> </ul>
 Mandatory	<ul style="list-style-type: none"> <li>▼ Turn off input power before wiring and setting switches.</li> <li>▼ Turn off the power immediately in case of any abnormalities such as smoke, smell or abnormal noise. Neglect of these conditions may lead to fire. For repairs, call your sales/repair agency.</li> </ul>



■ Transportation and installation

 <b>Danger</b>	
 Prohibited	<ul style="list-style-type: none"> <li>▼ Do not install or operate the inverter if it is damaged or any part of it is missing. Operating a defective inverter may lead to electric shocks or fire. For repairs, call your sales/repair agency.</li> <li>▼ Do not put any flammable material near the product. It may catch fire due to the product sparking in the case of a malfunction.</li> <li>▼ Do not install in any location where the inverter may comes into contact with water or other fluids. It may lead to electric shocks or fire.</li> <li>▼ When installing this option, be careful not to touch the leads from parts on the reverse side of its circuit board. It may lead to injury.</li> </ul>
 Mandatory	<ul style="list-style-type: none"> <li>▼ Operate under the environmental conditions prescribed in the instruction manual. Operations under any other conditions may lead to malfunction.</li> </ul>



## ■ Wiring

 <b>Danger</b>	
 Mandatory	<ul style="list-style-type: none"> <li>▼ Turn off input power before installing and wiring this option. Wait at least 15 minutes and check to make sure that the charge lamp (VF-AS1/PS1) is no longer lit.</li> <li>▼ Tighten the screws on the terminal block to the specified torque (Refer to Section 3.2). If the screws are not tightened to the specified torque, it may lead to fire.</li> <li>▼ Electrical construction work must be done by a qualified expert. Installation or connection of input power by someone who does not have that expert knowledge may lead to fire or electric shocks.</li> </ul>

## ■ Operations

 <b>Danger</b>	
 Prohibited	<ul style="list-style-type: none"> <li>▼ Do not touch switches when the hands are wet and do not try to clean the inverter with a wet cloth. It may lead to electric shocks.</li> <li>▼ Do not pull on any cable itself. It may lead to damage or malfunction.</li> </ul>

## ■ Disposal

 <b>Warning</b>	
 Mandatory	<ul style="list-style-type: none"> <li>▼ If you dispose off this unit, have it done by a specialist in industrial waste disposal*. Improper disposal may result in explosion of capacitors or produce noxious gases, resulting in injury. (* ) Persons who specialize in the processing of waste and known as “Industrial Waste Product Collectors and Transporters” or “Industrial Waste Disposal Persons.” If the collection, transport and disposal of industrial waste is done by someone who is not licensed for that job, it is a punishable violation of the law (Laws in regard to cleaning and processing of waste materials).</li> </ul>

## Notes on use

<b>Notes</b>	
	<ul style="list-style-type: none"> <li>▼ Avoid installing in a place where ambient temperature or/and humidity change sharply.</li> <li>▼ Keep the communication cable separate and from the power cable of the inverter to prevent the inverter from malfunctioning due to electromagnetic noise.</li> <li>▼ Please make grounding of a network SLD terminal different from grounding an inverter and a motor. It becomes the cause of the malfunction by the noise.</li> <li>▼ Insert a magnetic contactor or similar device between the inverter and the power supply to ensure that power is turned off if an emergency stop command is entered through the externally.</li> </ul>

# Preface

Thank you for purchasing a "CC-Link Option (CCL001Z1)" for TOSVERT VF-AS1/PS1 inverter.

This option can connect with open field network CC-Link and data communications with the CC-Link master through installing this option in the VF-AS1/PS1 and using it. Besides this instruction manual, the "CC-Link option Function Manual" is required to develop software communicating with VF-AS1/PS1. In such a case, please get in touch with our branch offices or sales offices. ("CC-Link option Function Manual": E6581477).

This manual is also aimed at the operator using "VF-AS1/PS1 CC-Link option", so please use it for future maintenance and inspection.

## ■ Explanation of model number of CC-Link option

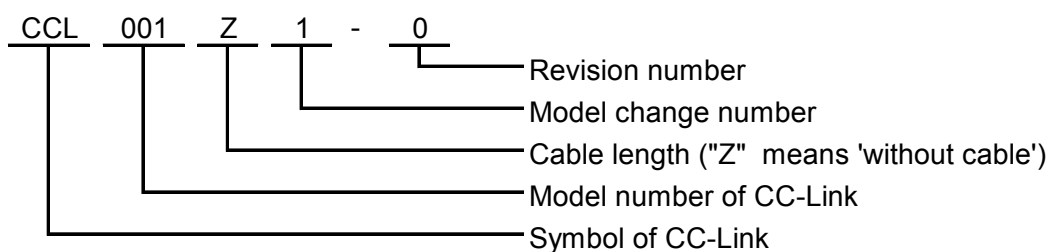

## ■ Accessory check list

CC-Link option is shipped together with the following items in the package. Contact your sales agency if any of these is missing.

- (1) VF-AS1/PS1 CC-Link option (CCL001Z1)..... 1 board  
 (Terminal connector : MCVW1,5/5-STF-3.5)  
 : PHOENIX CONTACT.....1 piece

- (2) Instruction manual for the VF-AS1/PS1 CC-Link option  
 .....1 copy

( English: E6581476  
 (This manual) )

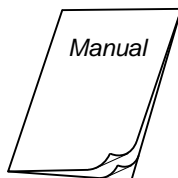

- (3) LED name label .....1 sheet

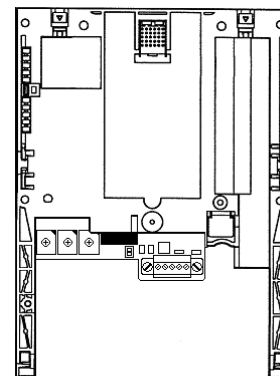
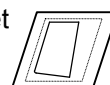

---

## — Table of contents —

---

1. Overview.....	6
2. Name of functions of main parts .....	6
2.1. Exterior features.....	6
2.2. Set the station No. and baud rate .....	7
2.3. About indicator of LED .....	7
2.4. CC-Link connector .....	8
3. Installing the CCL001Z1.....	9
3.1. Case of installing two options .....	1 1
3.2. Connection of CC-Link cable .....	1 1
3.3. About a terminal resist change switch(SW6).....	1 1
3.4. Wiring / Connection with the CC-Link master.....	1 2
4. Functions.....	1 3
4.1. Initial setting .....	1 3
4.2. Basic functions .....	1 4
5. Unusual diagnosis .....	1 5
5.1. Option error .....	1 5
5.2. Disconnection error of network cable .....	1 5
6. List of CC-Link data.....	1 6
6.1. RX(Monitor), RY(Instruction).....	1 6
6.2. RWr, RWw resister.....	1 7
6.3. Monitor code .....	1 7
6.4. Instruction Codes .....	1 9
6.5. Reply Code .....	2 0
7. CC-Link local/Remote Operation .....	2 0
8. Specifications .....	2 1
9. Warranty.....	2 1

## 1. Overview

This option allows the VF-AS1/PS1 inverter to be connected into a CC-Link network. CC-Link supports a maximum of 42 nodes, allowing for the Master unit and this option is based on CC-Link Ver.1.10.

The CCL001Z1 is able to operate RUN/STOP, monitor the status of the inverter, set the inverter's parameter and etc. by the CC-Link master through installing the VF-AS1/PS1. And it can use various applications.

## 2. Name of functions of main parts

Here are the name and functions of the exterior components of the CCL001Z1 unit.

### 2.1. Exterior features

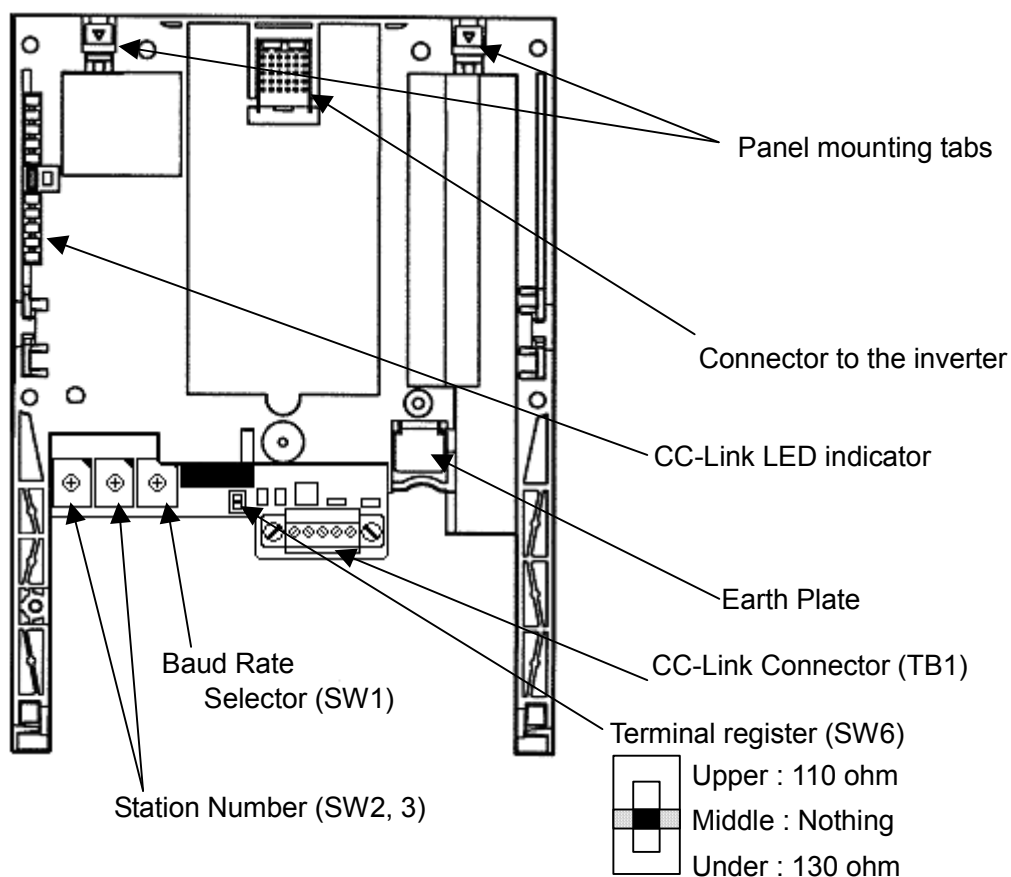

## 2.2. Set the station No. and baud rate

For the setting station number or communication speed to take effect, power needs to be turned off and then turned back on.

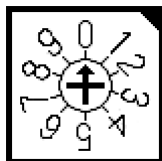

x10 (SW2)

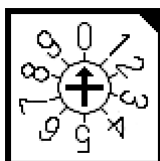

x1 (SW3)

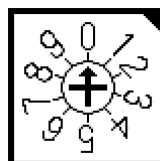

BAUD RATE (SW1)

Rotary switches for the setting up a station No.

Rotary switch for the setting up a baud rate

- Set the Station No.

The station number is able to set between 1 and 64.

The switch x10 is set up the ten's place and x1 is set up the ones.

Set the arrow (↑) of the corresponding switch to the required numeral.

- Set the baud rate. (For details, refer to the CC-Link master unit manual.)

Setting Switch	0	1	2	3	4
Transmission Speed	156kbps	625kbps	2.5Mbps	5Mbps	10Mbps

\*It causes an error when the switches are not set correct position (ex. set position between 0 and 1 switch label), or set over 5.

## 2.3. About indicator of LED

The LED shows the present status of the network and error.

C C L i n k	Power	Light on during transmission period.
	L.RUN	Light on during communication.
	SD	Light on during send the data of CC-Link.
	RD	Light on during receive the data of CC-Link
	L.ERR	Light on during communication error

### ■ Layout of LED

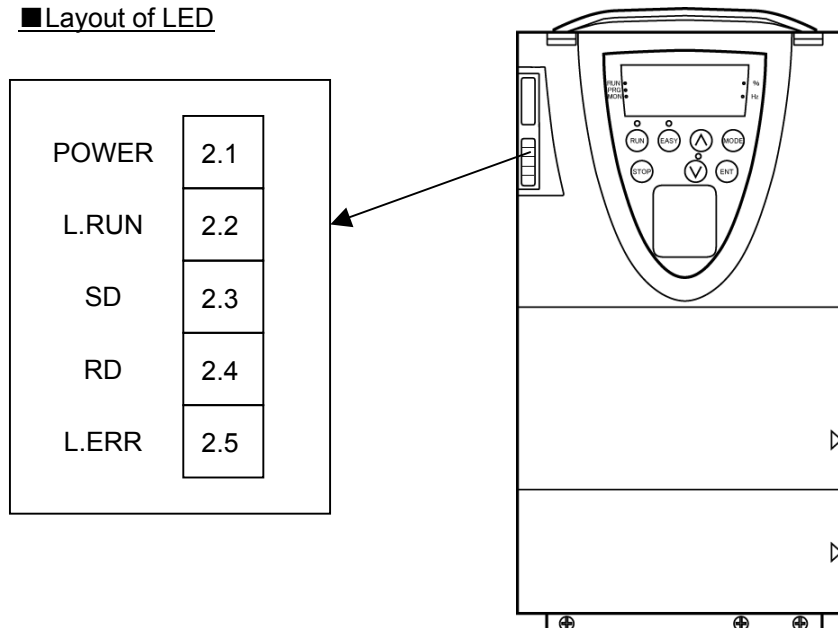



## Behavior of LED

State of LED				Cause
L.RUN	SD	RD	L.ERR	
●	⊙	⊙	⊙	Normal communication is made but CRC error has occurred due to noise.
●	⊙	⊙	○	Normal communication
●	⊙	○	⊙	Hardware fault
●	⊙	○	○	Hardware fault
●	○	⊙	⊙	Can not answer due to CRC error of receive data.
●	○	⊙	○	Data sent to the host station does not reach destination.
●	○	○	⊙	Hardware fault
●	○	○	○	Hardware fault (It is an unstable state by disconnection, etc.)
○	⊙	⊙	⊙	Polling response is made but refresh receive is error in CRC.
○	⊙	⊙	○	Hardware fault
○	⊙	○	⊙	Hardware fault
○	⊙	○	○	Hardware fault
○	○	⊙	⊙	Data sent to the host station is error in CRC.
○	○	⊙	○	There is no data sent to the host station, or data sent to the host station cannot be received to noise.
○	○	○	⊙	Hardware fault
○	○	○	○	Cannot receive data due to break in the cable, etc.
○	○	⊙ or ○	●	Invalid baud rate or station number setting
●	⊙	⊙	⊙	Baud rate or station number was changed during operation.
○	○	○	○	WDT error occurrence (hardware fault), power off, etc.

● : On      ○ : Off      ⊙ : Flicker

## 2.4. CC-Link connector

Below figure is the terminal to connect the CC-Link cable. Connection is screw connection. The terminal is a plug-type and the signal of each terminal is as follows.

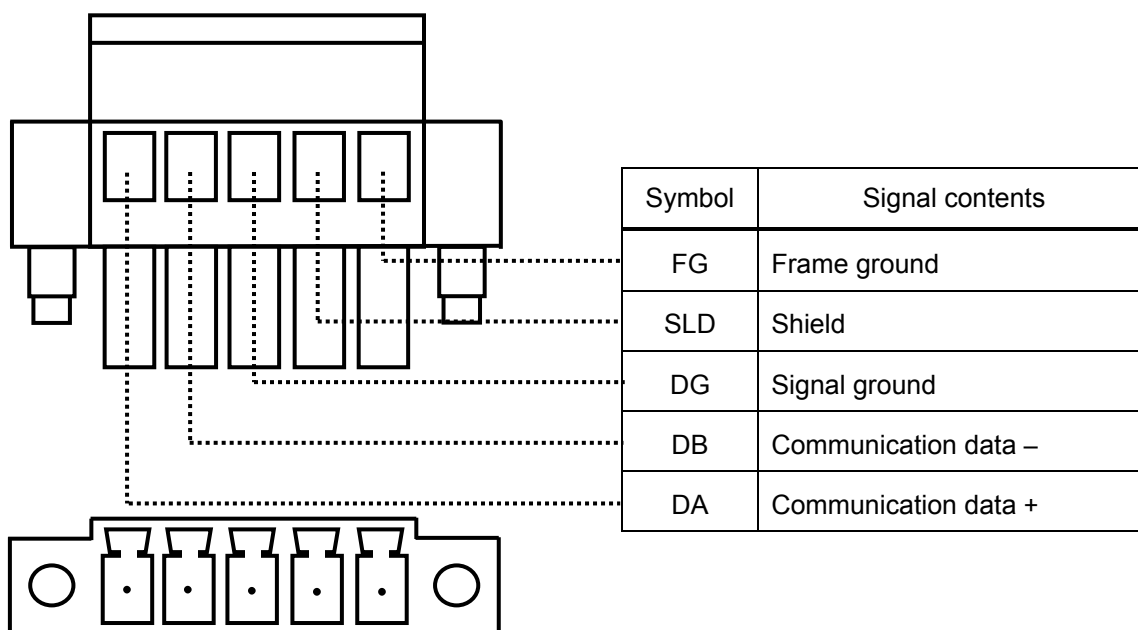

### 3. Installing the CCL001Z1



Mandatory

Turn off input power of VF-AS1/PS1 and wait for at least 15 minutes and then check that the CHARGE lamp on VF-AS1/PS1 is no longer lit.

Install the CC-Link option to VF-AS1/PS1 as follows.

\*1 When this option is used together with the I/O card option, attach this option to the front panel side.

(1) Check that all the power supplies to an inverter are turned off.

(2) Securing the option to the inverter

(A) For VFAS1/VFPS1 200V 45kW or less, 400V 75kW or less

- a) Insert a flat-blade screwdriver in each of the two holes at the upper part of the front panel, release the panel mounting tab by pushing the screwdriver down and remove the front panel cover.
- b) Install the option in the inverter by fitting the tabs on the lower side the option into the slots at the lower part of the inverter front panel.\*2
- c) Make sure the option is securely attached to the inverter. Then check whether the plastic bosses on the inverter case have fitted in the holes at the upper and lower parts of the option.
- d) Insert the tabs at the lower part of the front cover into the slots at the lower part of the inverter to attach the front cover to the inverter.\*2
- e) Stuck the enclosed "LED name label" in the option LED display part of a front cover

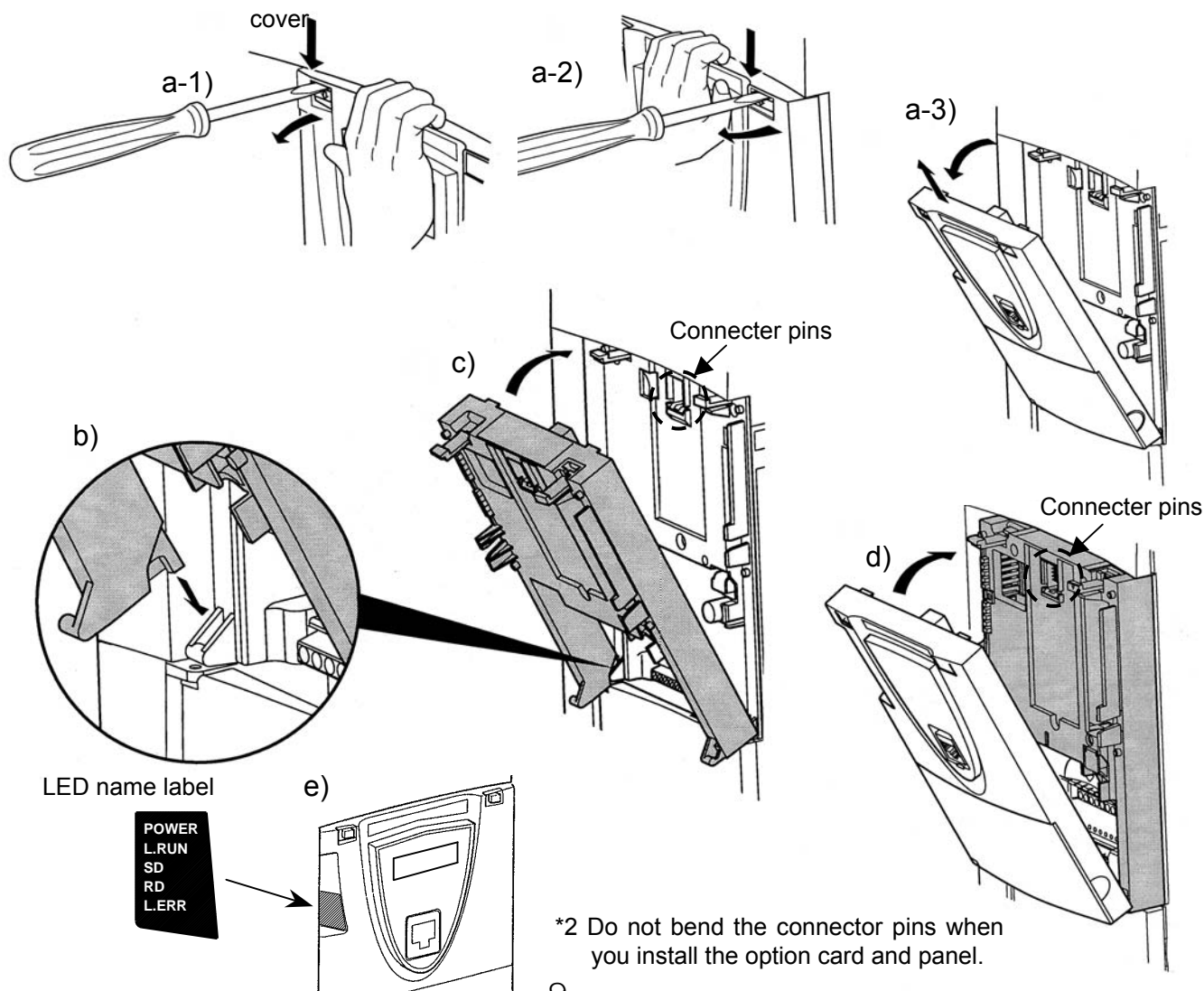

(B) For VFAS1/VFPS1 200V 55kW or more, 400V 90kW or more

- a) Insert a flat-blade screwdriver in each of the two holes at the upper part of the front panel, release the panel mounting tab by pushing the screwdriver down, and remove the front panel cover.
- b) Push the hooks pointed by the arrows and remove the standard option case.
- c) Install the option in the inverter by fitting the tabs on the lower side of the option into the slots at the lower part of the inverter front panel. \*1
- d) Make sure the option is securely attached to the inverter. Then, check whether the plastic bosses on the inverter case have fitted in the holes at the upper and lower parts of the option.
- e) Insert the tabs at the lower part of the front cover into the slots at the lower part of the inverter to attach the front cover to the inverter. \*1
- f) Stuck the enclosed "LED name label" on the option LED display part of a front cover.

\*1 Do not bend the connector pins when you install the option card and panel.

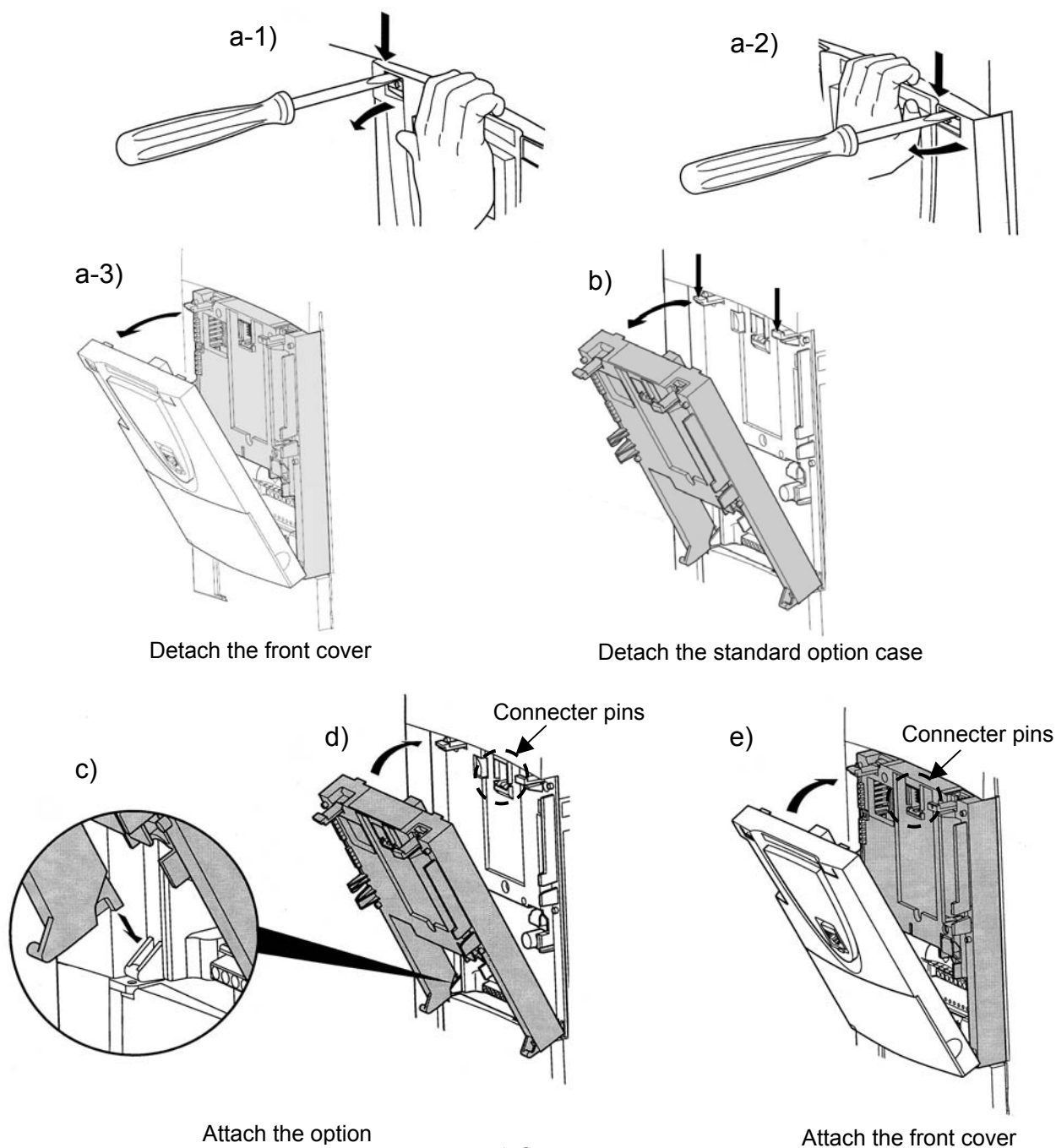

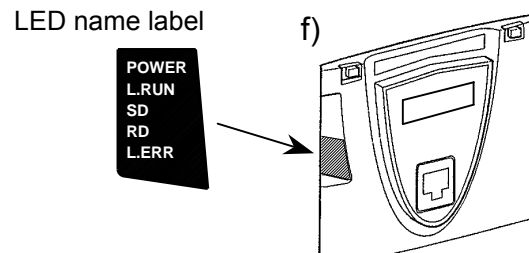

### 3.1. Case of installing two options

Please install this option (CCL001Z1) on the top of options when you install two options.  
Do not install under the another option.

### 3.2. Connection of CC-Link cable

If use other than the CC-Link dedicated cable, the performance of the CC-Link system is not guaranteed. Please ask a manufacture given in the product catalog of CC-Link association issue, or the "product information" on a CC-Link association homepage (<http://cc-link.org/>) about the details of the CC-Link dedicated cable.

Please use the recommended CC-Link dedicated cable. And strip the cable sheaths and twist the wires. If the sheath was stripped too long, the cable may contact with the adjacent cable and cause a short circuit. If the sheath was stripped too short, the cable may be not connected.

- Recommend screwdriver : A small flat-blade screwdriver  
(tip thickness 0.4mm, full length 2.5mm)
- Recommended tightening torque : 0.22 to 0.25 N·m
- Skin length : about 7mm

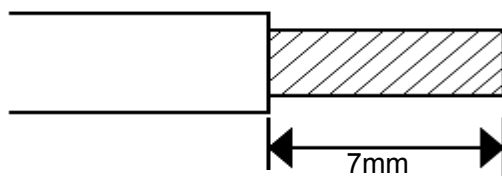

- \* Fix the communication cables after wiring.
- \* If take care of the wire end, use below parts.

Manufacture : Phoenix contact corp.  
 Part Number : AI 0,5-8 WH (connect one wire)  
 Part Number : AI-TWIN2x0,5-8 WH (connect two wires)  
 Length : 8mm

### 3.3. About a terminal resist change switch(SW6)

By switching SW6 in the left-hand side of a CC-Link terminal, a termination resistor (upper: 110ohms, under: 130ohms) can be switched. A termination resistor will not be connected if it sets up in the center.

### 3.4. Wiring / Connection with the CC-Link master

The example of wiring/connection with the CC-Link master unit is shown in the following figure.

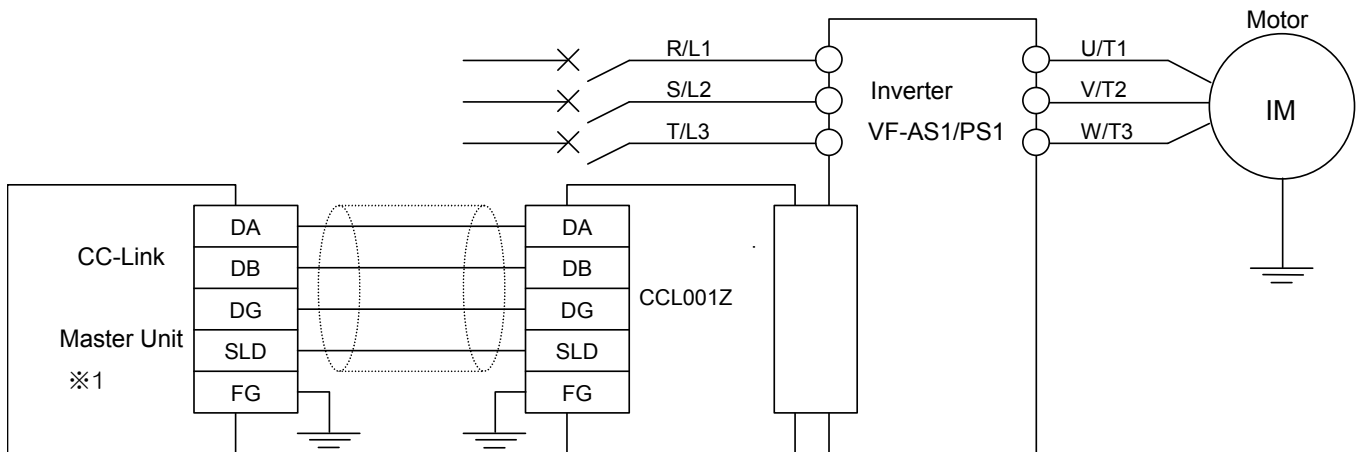

The example of wiring with the inverter VF-AS1/PS1

※1: As for master station, when use the Mitsubishi Electric An series, the recommended version is "LS" or

#### • Connection of Several Inverters

Factory Automation can be applied with several inverters which share CC-Link system as a remote device station, and are controlled and monitored by PLC user programs.

##### \* Communication terminal DA, DB

Set up the network using shielded twisted pair cable.

##### \* Communication terminal DG

##### \* Shield connection terminal SLD

Please connect the shield line of the dedicated CC-Link cable with the SLD terminal.

##### \* Connection of the frame ground terminal FG

Grounding resistance is 100 ohm max.

##### \* Termination resistor

Set SW6 to 110 ohm-termination resistor side.

(Note : Please use 130 ohm, 1/2W resistors when use the high performance CC-Link dedicated cable.)

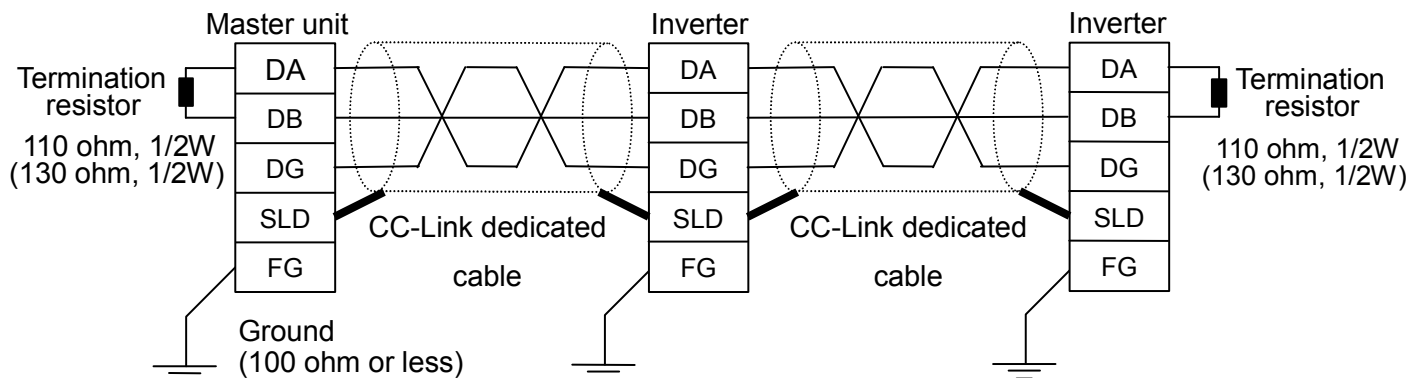

\* Maximum number of units connected to one master station is 42 units (when only inverters are connected).

\* If any other units are included, the number of occupied stations depends on the unit. So the connectable number of units is different.

## 4. Functions

This option is a communication interface unit that allows the PLC program to operate, monitor and set the parameter of the inverter as a remote station of CC-Link. It is able to communicate with a maximum speed of 10Mbps not only transmitting bit data but also by word data.

### 4.1. Initial setting

Set the following parameters of the inverter.

Name of parameter	Functions	Adjustment of range	Factory setting	CC-Link setting
<i>Cn0d</i>	Command mode selection	0: Terminal input enabled 1: Operation panel input enabled (including LED/LCD option input) 2: 2-wire RS485 communication input 3: 4-wire RS485 communication input 4: Communication option input	0	4
<i>Fn0d</i>	Frequency setting mode selection 1	1: VI/II (voltage/current input) 2: RR/S4 (potentiometer/voltage input) 3: RX (voltage input) 4: Operation panel input enabled (including LED/LCD option input) 5: 2-wire RS485 communication input 6: 4-wire RS485 communication input 7: Communication option input 8: Optional AI1 (differential current input) 9: Optional AI2 (voltage/current input) 10: Up/Down frequency 11: Optional RP pulse input 12: Optional high-speed pulse input 13: *1	2	7
<i>F420</i>	Torque command selection	1: VI/II (voltage/current input) 2: RR/S4 (potentiometer/voltage input) 3: RX (voltage input) 4: Operation panel input enabled (including LED/LCD option input) 5: 2-wire RS485 communication input 6: 4-wire RS485 communication input 7: Communications option input enabled 8: Optional AI1 (differential current input)	3	*2

\*1 Unsupported item.

\*2 Change the setting of F420 if necessary.

---

## 4.2. Basic functions

---

This clause shows the basic function of this CC-Link option using by CC-Link communication.

---

### 4.2.1. Run and frequency operation command

---

The PLC program can operate the inverter to run, stop, set the operation frequency and change the parameters.

If the PLC controls these operations, select the command mode and the frequency setting mode. (Change the setting of the torque command selection if necessary.)

The parameter setting of the inverter

Command mode selection

**C70d** : 4[Communication option input] (Factory setting: 0)

Frequency setting mode selection

**F70d** : 7[Communication option input] (Factory setting: 2)

Torque command selection

**F420** : 7[Communication option input] (Factory setting: 3)

---

### 4.2.2. Monitor

---

It is able to monitor the status of the inverter.

Set the monitor code to RWwn and turn RYnC on. The data is stored in the buffer memory of the PLC.

\* "n" is depend on the station number.

- Refer to "Section 6. List of CC-Link data" about the monitor code and unit.

---

### 4.2.3. Writing and reading the parameter

---

The PLC can read, write the inverter parameters and reset the inverter.

Set the command code to RWw(n+2) (set the data to RWw(n+3) if necessary) and turn RYnF (instruction code execution request) on. The inverter performs processing corresponding to the command code, and return the response data, the read out data and RXnF (instruction code execution completion).

- Refer to the "CC-Link Option Function Manual E6581477" for the command code, the unit of the data, and the setting range.

## 5. Unusual diagnosis

The VF-AS1/PS1 is able to install two kind options. The option error message is depended on the position of the option under or panel side.

### 5.1. Option error

The error message is displayed when there is hardware error, software error or lose of connection of wire.

#### ▼Display of trip information

**E - 23** (Error code : 55) : Add-on option 1 error

(This error is displayed at the time the bottom side option has an error or only one option is installed and has an error.)

**E - 24** (Error code : 56) : Add-on option 2 error

(This error is displayed at the time the two-units are installed and the upper side option has an error.)

### 5.2. Disconnection error of network cable

#### ▼Display of trip information

**E r r B** (Error code : 27) : Communication error

#### ▼Related parameter

**[F850** Disconnection detection extended time]

The range : 0.0 to 100.0 sec.

The waiting time from when a network error occurs to when a communication error "E r r B" is displayed can be adjusted. If a network error continues past the time set in **F850**, it is recognized as a communication error and "E r r B" is displayed.

When normal communication returns during the set time, a communication error is not displayed and operation is continued.

**[F851** Inverter operation at disconnection]

The range 0: Stop and Communication release

(C n o d, F n o d)

1: None (continued operation)

2: Deceleration stop

3: Coast stop

4: Network error (E r r B trip)

5: Preset speed operation (by **F852** setting)

The action of the inverter when the communication error occurred can be specified.

**[F852** Preset speed operation selection]

Setting range 0 : None

1 to 15 : Preset speed operation (by parameter setting)



## 6. List of CC-Link data

This option occupies one station area of the buffer memory of the PLC.

### 6.1. RX(Monitor), RY(Instruction)

List of remote I/O

Inverter (Slave) -> PLC (Master)		PLC (Master) -> Inverter (Slave)	
Device No.	Signal	Device No.	Signal
RXn0	Forward running	RYn0	Forward rotation command
RXn1	Reverse running	RYn1	Reverse rotation command
RXn2	Output terminal function selection 1 (OUT1)	RYn2	Input terminal function selection 5 (S1)
RXn3	Output terminal function selection 2 (OUT2)	RYn3	Input terminal function selection 6 (S2)
RXn4	Output terminal function selection 3 (FL)	RYn4	Input terminal function selection 7 (S3)
RXn5	Output terminal function selection 4 (OUT3)	RYn5	Input terminal function selection 8 (S4)
RXn6	Output terminal function selection 5 (OUT4)	RYn6	Input terminal function selection 9 (L1)
RXn7	Output terminal function selection 6 (R1)	RYn7	Input terminal function selection 10 (L2)
RXn8	Output terminal function selection 7 (OUT5)	RYn8	Input terminal function selection 11 (L3)
RXn9	Output terminal function selection 8 (OUT6)	RYn9	Intercept output to inverter (Coast stop)
RXnA	Output terminal function selection 9 (R2)	RYnA	Frequency priority CC-Link
RXnB	Reserved	RYnB	Command priority CC-Link
RXnC	Monitoring	RYnC	Monitor command
RXnD	Frequency setting completion (RAM)	RYnD	Frequency setting command
RXnE	Torque setting completion (RAM)	RYnE	Torque setting command (RAM)
RXnF	Instruction code execution completion	RYnF	Instruction code execution request
RX(n+1)0	Reserved	RY(n+1)0	Reserved
RX(n+1)1		RY(n+1)1	
RX(n+1)2		RY(n+1)2	
RX(n+1)3		RY(n+1)3	
RX(n+1)4		RY(n+1)4	
RX(n+1)5		RY(n+1)5	
RX(n+1)6		RY(n+1)6	
RX(n+1)7		RY(n+1)7	
RX(n+1)8		RY(n+1)8	
RX(n+1)9		RY(n+1)9	
RX(n+1)A	Error status flag	RY(n+1)A	Error reset request flag *2
RX(n+1)B	Remote station ready	RY(n+1)B	Reserved
RX(n+1)C	Reserved	RY(n+1)C	
RX(n+1)D		RY(n+1)D	
RX(n+1)E		RY(n+1)E	
RX(n+1)F		RY(n+1)F	

"n" is depend on the station number.

\*1 The reserved input signal should be set OFF ("0").

\*2 A reset request is during switched ON.

## 6.2. RWr, RWw resister

RWr . RWw (Default value = 0)

Inverter → PLC (RWr)		PLC → Inverter (RWw)	
Address	Contents	Address	Contents
RWr n	First monitor value	RWw n	Monitor code (first and second)
RWr n+1	Second monitor value (output frequency)	RWw n+1	Set frequency/ torque
RWr n+2	Reply code	RWw n+2	Instruction code
RWr n+3	Read data	RWw n+3	Write data

"n" is depend on the station number.

## 6.3. Monitor code

Divide the monitor code (RWw n) into half and select the first monitor data (RWr n) from the lower 8 bits and the second monitor data (RWr n) from the higher 8 bits.

(Example) When output voltage is selected for the first monitor and output torque is selected for the second monitor. → The monitor code is 0703H.

RWw n	Monitor code
the higher 8 bits	the lower 8 bits
Second monitor description	First monitor description

\* The hexadecimal value attaches and expresses "H" to the end of a number.

Monitor code (When an invalid monitor code is set up, monitor value fixes to 0.)

Code Number	Second Monitor Description (the higher 8 bits)	First Monitor Description (the lower 8 bits)	Unit
00H	Output frequency	None monitor (Monitor value is 0)	0.01Hz
01H	Output frequency	Output frequency	0.01Hz
02H *1	Output current	Output current	0.01A
03H	Output voltage	Output voltage	0.1V
04H	None monitor (Monitor value is 0)	None monitor (Monitor value is 0)	—
05H	Frequency command value	Frequency command value	0.01Hz
06H	Output speed *2	Output speed *2	1min <sup>-1</sup>
07H	Output torque	Output torque	0.1%
08H	DC voltage	DC voltage	0.1V
09H	PBR load factor(FD28)	PBR load factor(FD28)	0.1%
0AH	Motor overload factor (OL2 data)	Motor overload factor (OL2 data)	0.1%
0BH, 0CH	None monitor (Monitor value is 0)	None monitor (Monitor value is 0)	—
0DH	Input power	Input power	0.01kW
0EH	Output power	Output power	0.01kW
0FH	Input terminal information	Input terminal information	—
10H	Output terminal information	Output terminal information	—
11H	Output current (% monitor)	Output current (% monitor)	0.1%
12H	Exciting current	Exciting current	0.01A
13H	None monitor (Monitor value is 0)	None monitor (Monitor value is 0)	—
14H	Cumulative operation time	Cumulative operation time	1hr
15H, 16H	None monitor (Monitor value is 0)	None monitor (Monitor value is 0)	—
17H	Accumulation power supply ON time	Accumulation power supply ON time	1hr
18H	Motor overload factor	Motor overload factor	0.1%
19H	Integral input power	Integral input power	1kWh
1AH	Integral output power	Integral output power	1kWh
1BH	RR/S4 input	RR/S4 input	—
1CH	VI/II input	VI/II input	—
1DH	RX input	RX input	—
1EH, 1FH	None monitor (Monitor value is 0)	None monitor (Monitor value is 0)	—
20H	Torque command	Torque command	0.1%
21H	Torque current	Torque current	0.1%
22H	None monitor (Monitor value is 0)	None monitor (Monitor value is 0)	—
23H	Speed feedback (real-time value) *3	Speed feedback (real-time value) *3	0.01H
24H	PID feedback value	PID feedback value	0.01Hz
25H	Speed feedback (1-second filter) *3	Speed feedback (1-second filter) *3	0.01H
26H to 2FH	None monitor (Monitor value is 0)	None monitor (Monitor value is 0)	—

Code Number	Second Monitor Description (the higher 8 bits)	First Monitor Description (the lower 8 bits)	Unit
30H	My function monitor 1	My function monitor 1	—
31H	My function monitor 2	My function monitor 2	—
32H	My function monitor 3	My function monitor 3	—
33H	My function monitor 4	My function monitor 4	—

\*1: The monitor code "02H" will be overflow when its value more than 327.67A. If that monitor overflowed, use the monitor code "11H".

\*2: This monitor function is VF-PS1 only.

\*3: These monitor functions are available with the option unit CPU software version 2.01 or later.

## 6.4. Instruction Codes

Code No.	Contents		Description
1003H	Command mode selection read		0 : Terminal input enabled 1 : Operation panel input enabled (including LED/LCD option input)
2003H	Command mode selection write		2 : 2-wire RS485 communication input 3 : 4-wire RS485 communication input 4 : Communication option input
1004H	Frequency setting mode selection read		1 : VI/II (voltage/current input) 2 : RR/S4 (potentiometer/voltage input) 3 : RX (voltage input) 4 : Operation panel input enabled (including LED/LCD option input)
2004H	Frequency setting mode selection write		5 : 2-wire RS485 communication input 6 : 4-wire RS485 communication input 7 : Communication option input 8 : Optional AI1 (differential current input) 9 : Optional AI2 (voltage/current input) 10 : UP/DOWN frequency 11 : Optional RP pulse input 12 : Optional high-speed pulse input 13 : *
0072H	Special monitor		0000H~FFFFH : Monitor value selected after choosing instruction code 00F3H.
0073H	read	Special monitor code read	Read the content that was monitored by special monitor.
00F3H	write	Special monitor selection	Select the monitor code of special monitor.
0074H	Trip history No.1, No.2 read		Read the No.1(latest) to No.4(oldest) trip records.
0075H	Trip history No.3, No.4 read		
006DH	Frequency command value (RAM) read		Read the frequency command value (RAM).
006EH	Torque command value (RAM) read		Read the torque command value (RAM).
00EDH	Option frequency command value (EEPROM&RAM) write		Write the option frequency command value (EEPROM &RAM).
00EEH	Option torque command value (EEPROM&RAM) write		Write the option torque command value (EEPROM&RAM).
00F4H	Trip history clear		9696H : Clear all trip history.
00FCH	Parameter all clear		9696H : Clear all parameters. (Parameters other than proofread values are made into factory's default settings.)
00FDH	Inverter reset		9696H : Reset the inverter.
1000H to 1999H (1000H to 1F99H)	Read parameters (RAM)		To read parameters F000 to F984, add the triple figures that follow Fxxx to 1000H. (Ex: F984 -> 984 + 1000 = 1984) No error occurs when you select 1A00 to 1F99. Because these parameters are for maintenance.
2000H to 2999H	Write parameters (EEPROM&RAM)		To write parameters F000 to F984, add the triple figures that follow Fxxx to 2000H.

\* Unsupported item.

## 6.5. Reply Code

Reply code

Data	Item	Detailed contents
0000H	Normal (No error)	Normal completion of instruction code execution
0001H	Write error	Execution error. (Write protected during operation)
0002H	Parameter selection error	Unregistered code number was set.
0003H	Setting range error	Set data is outside the setting data range.

## 7. CC-Link local/Remote Operation

The example below shows how to configure the VF-AS1/PS1 for local/remote operation.

F terminal.....Operating command

R terminal .....CC-Link local/remote (Terminal in this example) switching

RR/S4 terminal .....Operation frequency command

<Wiring>

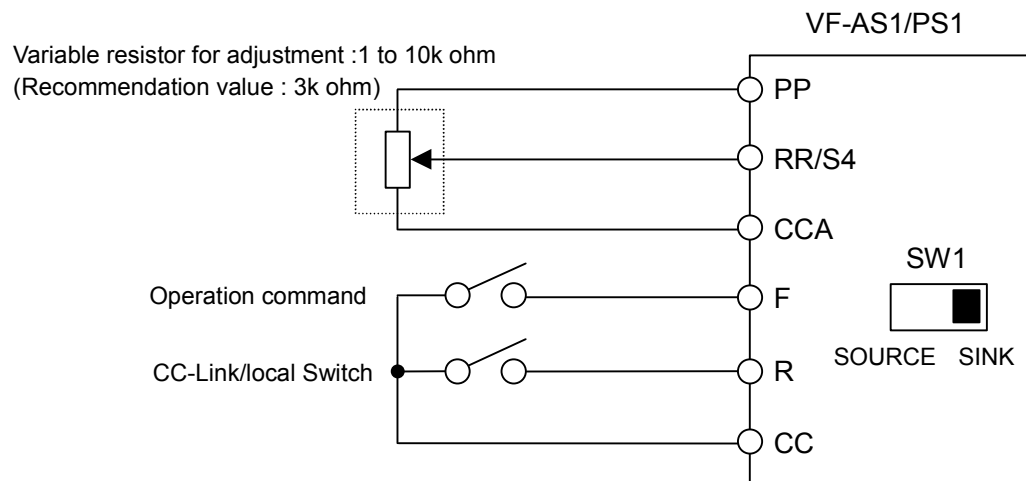

<Parameter setting>

$F 1 0 0$  (Command mode selection) =  $0$  (Terminal board)

$F 1 0 1$  (Frequency setting mode selection 1) =  $2$  (RR/S4)

$F 1 1 2$  (Input terminal selection 2 (R)) =  $4 B$  (Remote/Local control)

<Operation>

R-CC terminal open: VF-AS1/PS1 is controlled as a slave device of CC-Link.

R-CC terminal closed:

F-CC terminal short to RUN

F-CC terminal short to STOP

Output frequency is set up by the RR/S4 signal input.

## 8. Specifications

Item	Specifications
Model number	CCL001Z1
Station type	Remote device station
Number of occupied stations	1 station occupied by 1 unit
Baud rate	156kbps, 625kbps, 2.5Mbps, 5Mbps, 10Mbps
Power supply	Supplied from the inverter
Use environments	Indoors, an altitude of 3000m or less, where the product will not be exposed to direct sunlight, corrosive or explosive gasses, vapor, coarse particulate including dust, and where there is no grinding or grinding oil nearby.
Ambient temperature	0 to +60°C
Storage temperature	-25 to +65°C
Relative humidity	20 to 93% (No condensation and absence of vapor)
Vibration	5.9 m/s <sup>2</sup> {0.6G} or less (10 – 55Hz)

## 9. Warranty

Any part of the unit that proves defective will be repaired free of charge under the following conditions:

1. This warranty applies only to the option unit.
2. Any part of the option unit which fails or is damaged under normal use within twelve months from the date of delivery shall be repaired free of charge.
3. For the following kinds of failure or damage, the repair cost shall be borne by the customer even within the warranty period.
  - 1) Failure or damage caused by improper or incorrect use or handling, or unauthorized repair or modification of the option unit.
  - 2) Failure or damage caused by the option unit falling or an accident during transportation after the purchase.
  - 3) Failure or damage caused by fire, salty water or wind, corrosive gas, earthquake, storm or flood, lightning, abnormal voltage supply, or other natural disasters.
  - 4) Damage due to the use of CC-Link communication option for non-intended purposes.
4. Unless a service contract is signed beforehand between the customer and Toshiba, in which case the service contract has priority over this warranty.