

# MITSUBISHI

## High Speed Counter Module

### Type A1SD62, A1SD62E, A1SD62D

## User's Manual

(Hardware)

Thank you for buying the Mitsubishi general-purpose programmable logic controller MELSEC-A Series

Prior to use, please read both this manual and detailed manual thoroughly and familiarize yourself with the product.



©1995 MITSUBISHI ELECTRIC CORPORATION

MODEL	A1SD62-U(H/W)-E
MODEL CODE	13J811
IB(NA)-66588-D(0209)MEE	

### SAFETY PRECAUTIONS

(Read these precautions before using.)

When using Mitsubishi equipment, thoroughly read this manual and the associated manuals introduced in the manual. Also pay careful attention to safety and handle the module properly.

These precautions apply only to Mitsubishi equipment. Refer to the CPU module user's manual for a description of the PC system safety precautions.

These SAFETY PRECAUTIONS classify the safety precautions into two categories: "DANGER" and "CAUTION".

**DANGER** Procedures which may lead to a dangerous condition and cause death or serious injury if not carried out properly.

**CAUTION** Procedures which may lead to a dangerous condition and cause superficial to medium injury, or physical damage only, if not carried out properly.

Depending on circumstances, procedures indicated by CAUTION may also be linked to serious results.

In any case, it is important to follow the directions for usage.

Store this manual in a safe place so that you can take it out and read it whenever necessary. Always forward it to the end user.

### DESIGN PRECAUTIONS

#### DANGER

- Failure of external output transistors could cause outputs to remain continually ON or continually OFF. Provide an external circuit to monitor output signals whose disruption could cause serious accidents.

#### CAUTION

- Do not bundle the control wire and the communication cable with the main circuit or power line or keep them close to one another. Keep the control wire and the communication cable at least 150 mm away from the main circuit or power line: otherwise, noise or malfunctions will occur.

### INSTALLATION PRECAUTIONS

#### CAUTION

- Use the PC in the environment specified in the General Specifications section in this manual. Using it in an environment which does not meet the general specifications could cause electric shock, fire or malfunctions, and damage or deterioration of the module.
- Install the module by engaging the module mounting projections on the lower part of the module in the mounting holes of the base unit. Incorrect installation could result in malfunctions, failure of detachment.

### WIRING PRECAUTIONS

#### CAUTION

- The twisted shielded wire must be grounded to at least class 3 specifications at the encoder side (relay box).
- Ground the AG terminal using third class grounding or higher exclusively for the PC. If you do not, the PC will malfunction.
- Before connecting wires to the PC, check the rated voltage and the terminal arrangement. Connecting power of a different voltage or wiring incorrectly will result in fire or failure.
- Do not apply the voltage higher than the value set with a jumper. Failure to observe this instruction will result in failure.
- Tighten the terminal screws to the specified torque. Loose terminal screws will cause a short, fire or malfunctions. Tightening the terminal screws too far may cause damage to the screws resulting in short circuits or malfunctions.
- Take all possible measures to prevent chips or wire scraps from entering the module. Entry of foreign material will cause fire, failure of malfunctions.

### STARTING AND MAINTENANCE PRECAUTIONS

#### DANGER

- Do not touch the terminals while they are live. This will cause malfunctions.
- Switch the power off before cleaning the module or retightening the terminal screws. If the power is left on, the module will break down or malfunction.

#### CAUTION

- Do not disassemble or tamper with the module. This will cause failure, malfunctions, injuries or fire.
- Switch the power off before installing or removing the module. If the power is left on, the module will break down or malfunction.

### DISPOSAL PRECAUTIONS

#### CAUTION

- Dispose of the module as industrial waste.

### About This Manual

The following manuals are also related to this product. In necessary, order them by quoting the details in the tables below.

Detailed Manual

Manual Name	Manual No. (Type code)
A1SD62, A1SD62E, A1SD62D User's Manual	IB-66593 (13J816)

Please read A1SD62, A1SD62E and A1SD62D User's Manual before using this module.

### 1. GENERAL DESCRIPTION

This manual describes specifications, handling and wiring of an A1SD62, A1SD62E, A1SD62D high speed counter module (hereinafter referred to as the A1SD62 (E/D)).

### 2. PERFORMANCE SPECIFICATIONS

#### A1SD62 (E)

Item	Specifications			
Counting speed selection pin	100K side			10K side
Number of occupied I/O points	32			
Number of channels	2			
Count input signal	Phase	1-phase and 2-phase inputs		
	Signal levels (φ A and φ B)	5 VDC 12 VDC 24 VDC } 2 to 5 mA		
Counter	Maximum counting speed	1-phase input	100k pps	10k pps
		2-phase input	100k pps	7k pps
	Counting range	24-bit binary 0 to 16777215		
Counter	Type	Equipped with UP/DOWN preset counter and ring counter functions		
	Minimum count pulse width (Set input rise and fall times to 2.5 μs or less. Duty ratio: 50%)	Unit: μs 		Unit: μs 
Coincidence output	Comparison range	24-bit binary		
	Comparison result	Set value < count value Set value = count value Set value > count value		
External input	Preset	5/12/24 VDC		
	Function start	2 to 5 mA		
External output	Coincidence output	A1SD62	Transistor (sink type) output 12/24 VDC 0.5 A/point 2 A/common	
		A1SD62E	Transistor (source type) output 12/24 VDC 0.1 A/point 0.4 A/common	
Isolation specifications	Specific isolated area	Isolation method	Dielectric withstand voltage	Insulation resistance
	Between pulse input terminal and PLC power supply	Photocoupler isolation	500V AC/1 minute.	5M Ω or more by 500V DC insulation resistance tester.
	Between preset input terminal and PLC power supply			
	Between function start input terminal and PLC power supply			
Between coincidence output terminal and PLC power supply				
Applicable wire size	0.75 to 1.5 mm <sup>2</sup>			
Applicable solderless terminals	R1.25-3, 1.25-YS3, RAV1.25-3, V1.25-YS3A			
Internal current consumption (5 VDC)	0.1 A			
Weight kg (lb)	0.25 (0.55)			

\*1: The counting speed is influenced by the pulse leading edge/fall time.

The following counting speeds are possible. If a pulse is counted with a leading edge/fall time that is too long, a counter error may be caused.

Counting Speed Setting Pin	100k		10k	
	1-phase input	2-phase input	1-phase input	2-phase input
t=2.5 μs or less	100k pps	100k pps	10k pps	7k pps
t=25 μs or less	10k pps	10k pps	1k pps	700 pps
t=500 μs	—	—	500 pps	250 pps

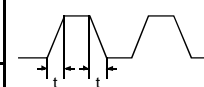

#### A1SD62D

Item	Specifications			
Counting speed selection pin	200K side		10K side	
Number of occupied I/O points	32			
Number of channels	2			
Count input signal	Phase	1-phase and 2-phase inputs		
	Signal levels (φ A and φ B)	EIA standard RS-422-A Differential driver level (equivalent to Am26LS31)		
Counter	Maximum counting speed	1-phase input	200k pps	10k pps
		2-phase input	200k pps	7k pps
	Counting range	24-bit binary 0 to 16777215		
Counter	Type	Equipped with UP/DOWN preset counter and ring counter functions		
	Minimum count pulse width (Set input rise and fall times to 1.25 or less. Duty ratio: 50%)	Unit: μs 		Unit: μs 
Coincidence output	Comparison range	24-bit binary		
	Comparison result	Set value < count value Set value = count value Set value > count value		
External input	Preset	5/12/24 VDC		
External output	Coincidence output	Function start		
		2 to 5 mA		
External output	Coincidence output	Transistor (sink type) output 12/24 VDC 0.5 A/point 2 A/common		
		Transistor (source type) output 12/24 VDC 0.1 A/point 0.4 A/common		
Photocoupler isolation	Specific isolated area	Isolation method	Dielectric withstand voltage	Insulation resistance
	Between pulse input terminal and PLC power supply	Photocoupler isolation	500V AC/1 minute.	5M Ω or more by 500V DC insulation resistance tester.
	Between preset input terminal and PLC power supply			
	Between function start input terminal and PLC power supply			
Between coincidence output terminal and PLC power supply				
Applicable wire size	0.75 to 1.5 mm <sup>2</sup>			
Applicable solderless terminals	R1.25-3, 1.25-YS3, RAV1.25-3, V1.25-YS3A			
Internal current consumption (5 VDC)	0.25A			
Weight kg (lb)	0.25 (0.55)			

\*1: The counting speed is influenced by the pulse leading edge/fall time.

The following counting speeds are possible. If a pulse is counted with a leading edge/fall time that is too long, a counter error may be caused.

Counting Speed Setting Pin	200k		10k	
	1-phase input	2-phase input	1-phase input	2-phase input
t=1.25 μs or less	200k pps	200k pps	10k pps	7k pps
t=12.5 μs or less	20k pps	20k pps	1k pps	700 pps
t=250 μs	—	—	500 pps	250 pps

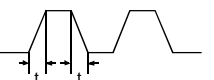

For the general specifications, refer to the User's Manual for the PC CPU used.

### 3. NOMENCLATURE

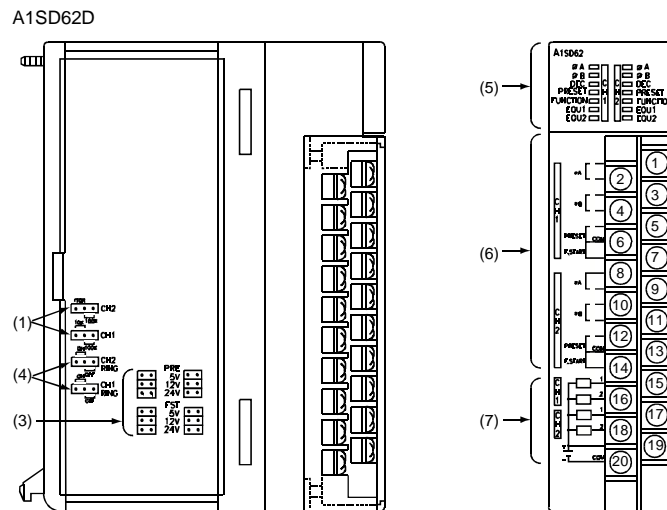
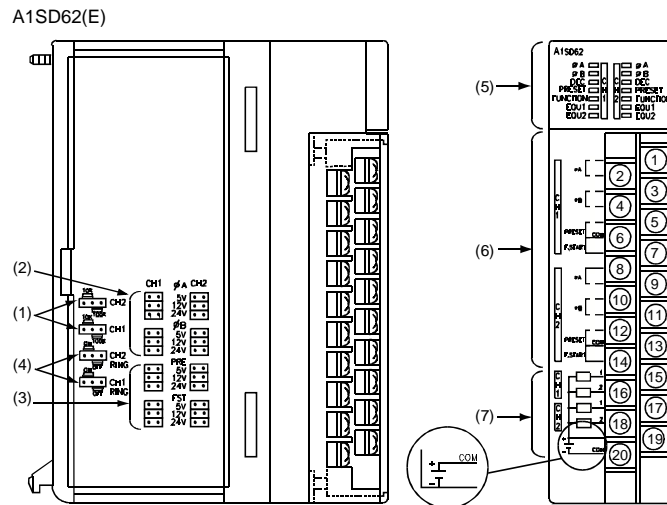

NO.	Name	Description
(1)	Counting speed selection pin 10k 100k	100(200)K: Counts pulses at a maximum speed of 100(200)k pps in 1-phase or 2-phase input. 10K: Counts pulses at 10k pps in 1-phase input, at 7k pps in 2-phase input. (The factory-setting is 100(200)k.) (Set with the jumper)
(2)	Input pulse voltage selection pin CH1 φA CH2 CH1 φB CH2 5V 12V 24V 5V 12V 24V	Select a pulse voltage that is input to Phase A or B. (The factory-setting is 24 V.) (Set with the jumper)
(3)	External input voltage selection pin PRE FST 5V 12V 24V 5V 12V 24V	Select a voltage input to the PRESET/F.START terminals. (The factory-setting is 24 V.) (Set with the jumper).
(4)	Ring Counter selection pin ON OFF CH2 RING CH1 RING	Set whether or not the ring counter function can be used. (The factory-setting is OFF.) (Set with the jumper)
(5)	φ A	Lit when voltage is applied to phase A pulse input terminal.
	φ B	Lit when voltage is applied to phase B pulse input terminal.
	DEC	Lit during subtraction.
	PRESET	Lit and latched when voltage is applied to the PRESET terminal. OFF when external preset detection reset signal (written to buffer memory 10, 42) is turned ON.
	FUNCTION	ON when voltage is applied to the F.START terminal.
	EQU1	Lit during channel 1 external coincidence output operation.
EQU2	Lit during channel 2 external coincidence output operation.	

NO.	Name	Description
(6)	φ A/ φ B	Pulse input terminals
	PRST	The terminal in which voltage is applied when a preset is executed from an external device.
	FST	The terminal in which voltage is applied when a counter function selection is executed.
(7)	Output terminals	EQU1 to 2 External output terminals for coincidence output.

### 4. LOADING AND INSTALLATION

#### 4.1 Cautions on Handling

- The case of the A1SD62/A1SD62E/A1SD62D is made of resin: do not drop it or subject it to strong impact.
- Do not remove the printed circuit board from the case. This could cause failure.
- Make sure that no wire cutoffs or other debris enters the top of the module during wiring. If anything does enter the module, remove it.
- Tighten the module mounting and terminal screws as specified below:

Screw	Tightening Torque Range N-cm [kg-cm] (lb-inches)
Module mounting screw (M4 screw)	78 to 118 [8 to 12] (6.93 to 10.4)
Terminal block terminal screw (M3.5 screw)	59 to 88 [6 to 9] (5.19 to 7.8)
Terminal block mounting screw (M4 screw)	78 to 118 [8 to 12]

#### 4.2 Installation Environment

Never install the A series in the following environment:

- Locations where the ambient temperature is outside the range of 0 to 55°C.
- Locations where the ambient humidity is outside the range of 10 to 90% RH.
- Locations where dew condensation takes place due to sudden temperature changes.
- Locations where there are corrosive and/or combustible gasses.
- Locations where there is a high level of conductive powder (such as dust and iron fillings, oil mist, salt, and organic solvents.)
- Locations exposed to the direct rays of the sun.
- Locations where strong power and magnetic fields are generated.
- Locations where vibration and shock are directly transmitted to the main module.

### 5. WIRING

The method for wiring pulse-generating equipment to the A1SD62(E/D) is described here.  
Be sure to use shielded twisted pair cables and ground twisted shield wire on the encoder side (joint box).

#### 5.1 Wiring example for the connection with the open collector output pulse generator

- Connection of a 24 VDC pulse generator

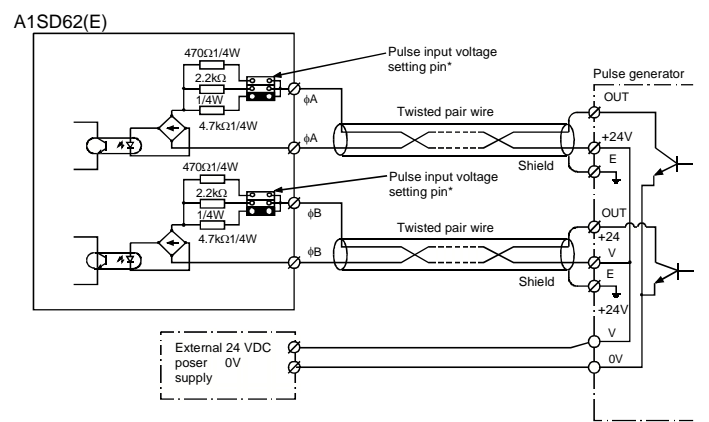

#### REMARK

- \* : Set the pulse input voltage setting pin to the **24V** position.
- (2) Connection of a voltage output pulse generator (5 VDC)

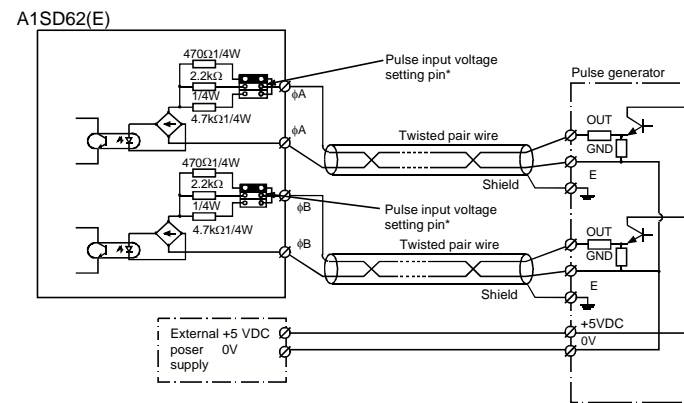

#### REMARK

- \* : Set the pulse input voltage setting pin to the **24V** position.
- (3) Example of wiring to line driver (Am26LS31 or equivalent) pulse generator

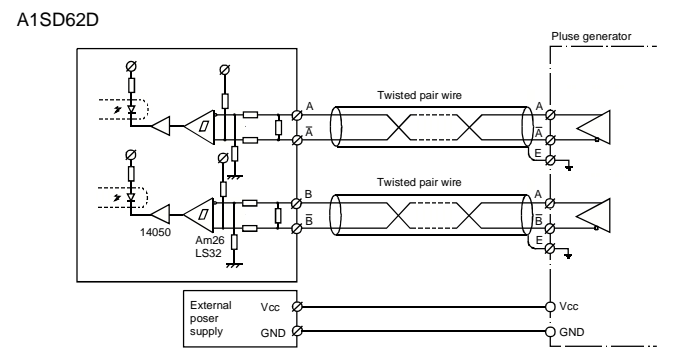

#### 5.2 Wiring Example for the Connection of a Controller to External Input Terminals (PRESET and F.START)

- When a controller (sink load type) is supplied with 12 V:

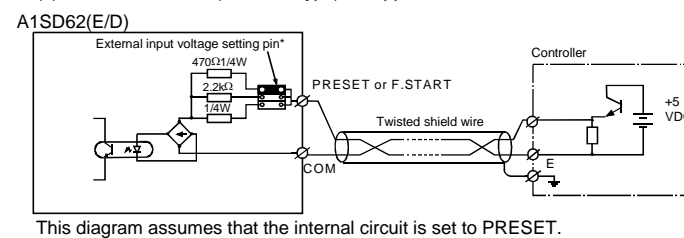

This diagram assumes that the internal circuit is set to PRESET.

- When a controller (source load type) is supplied with 5 V:

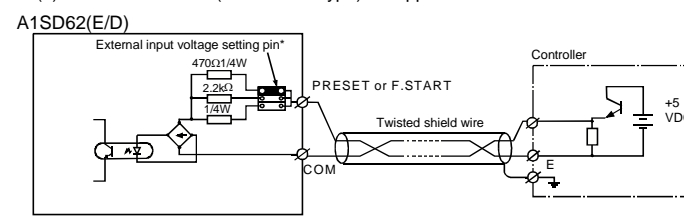

This diagram assumes that the internal circuit is set to PRESET.

#### REMARK

- \* : Set the external input voltage setting pin to the **5V** position.

#### 5.3 Wiring examples at external output terminals (EQUs 1 to 2)

To use an EQU terminal, the internal photocoupler should be activated. For this example, 10.2 to 30 VDC external power is necessary. Connection methods are as follows:

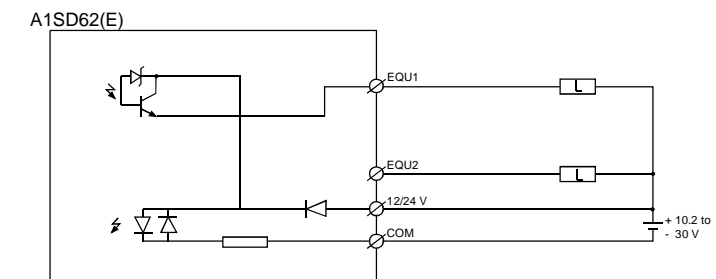
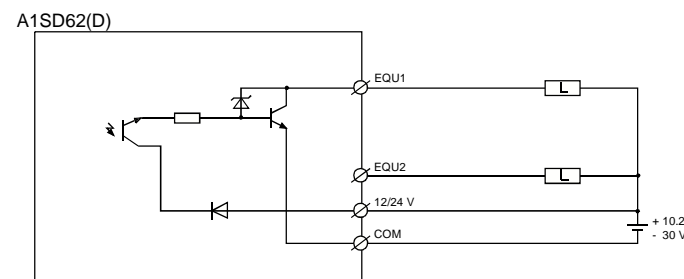

### 6. OUTSIDE DIMENSIONS

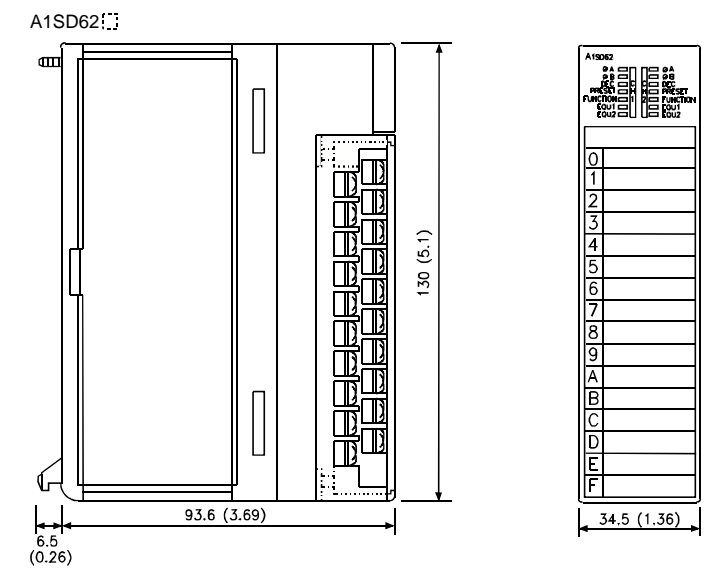

Unit: mm (Inch)

#### Warranty

Mitsubishi will not be held liable for damage caused by factors found not to be the cause of Mitsubishi; machine damage or lost profits caused by faults in the Mitsubishi products; damage, secondary damage, accident compensation caused by special factors unpredictable by Mitsubishi; damages to products other than Mitsubishi products; and to other duties.

#### For safe use

- This product has been manufactured as a general-purpose part for general industries, and has not been designed or manufactured to be incorporated in a device or system used in purposes related to human life.
- Before using the product for special purposes such as nuclear power, electric power, aerospace, medicine or passenger movement vehicles, consult with Mitsubishi.
- This product has been manufactured under strict quality control. However, when installing the product where major accidents or losses could occur if the product fails, install appropriate backup or failsafe functions in the system.

Country/Region	Sales office/Tel	Country/Region	Sales office/Tel
U.S.A	Mitsubishi Electric Automation Inc. 500 Corporate Woods Parkway Vernon Hills, IL 60061 Tel : +1-847-478-2100	China	Ryoden International Shanghai Ltd. 3F Block5 Building Automation Instrumentation Plaza 103 Cao Bao Rd. Shanghai 200233 China Tel : +86-21-6475-3228
Brazil	MELCO-TEC Rep. Com. e Assessoria Tecnica Ltda. Av. Rio Branco, 123-15, and S1507, Rio de Janeiro, RJ CEP 20040-005, Brazil Tel : +55-21-221-8343	Taiwan	Setuoy Enterprise Co., Ltd. 6F., No.105 Wu-Kung 3rd.RD, Wu-Ku Hsiang, Taipei Hsine, Taiwan Tel : +886-2-2299-2499
Germany	Mitsubishi Electric Europe B.V. German Branch Gothaer Strasse 8 D-40880 Ratingen, GERMANY Tel : +49-2102-486-0	Korea	HAN NEUNG TECHNO CO.,LTD. 1F Dong Seo Game Channel Bldg., 660-11, Deungchon-dong Kangsec-ku, Seoul, Korea Tel : +82-2-3660-9552
U.K	Mitsubishi Electric Europe B.V. UK Branch Travellers Lane, Hatfield, Herts., AL10 8XB, UK Tel : +44-1707-276100	Singapore	Mitsubishi Electric Asia Pte. Ltd. 307 ALEXANDRA ROAD #05-01/02, MITSUBISHI ELECTRIC BUILDING SINGAPORE 159943 Tel : +65-473-2480
Italy	Mitsubishi Electric Europe B.V. Italian Branch Centro Dir. Colleoni, Pal. Persico - Ingr.2 Via Paracelso 12, 20041 Agrate B., Milano, Italy Tel:+39-039-60531	Thailand	F. A. Tech Co. Ltd. 898/28,29,30 S.V. City Building Office Tower 2,Floor 17-18 Rama 3 Road, Bangkokpang, Yannawa, Bangkok 10120 Tel : +66-2-682-6522
Spain	Mitsubishi Electric Europe B.V. Spanish Branch Carretera de Rubi 76-80 08190 - Sant Cugat del Valles, Barcelona, Spain Tel:+34-935-653135	Indonesia	P.T. Autoteknik SLMBER MAKUMUR Jl. Muara Karang Selatan Block A Utara No.1 Kav. No.11 Kawasan Industri/ Pergudangan Jakarta - Utara 14440 Tel : +62-21-663-0833
South Africa	Circuit Breaker Industries LTD. Private Bag 2016, Isando 1600, Johannesburg, South Africa Tel : +27-11-928-2000	India	Measuring Systems Pvt.Ltd. Electronic Sadan NO:111 Unit No15, M.I.D.C BHOSARI,PUNE-411026 Tel : +91-20-7128927
Hong Kong	Ryoden Automation Ltd. 10th Floor, Manulife Tower, 169 Electric Road, North Point, HongKong Tel : +852-2887-8870	Australia	Mitsubishi Electric Australia Pty. Ltd. 348 Victoria Road, PostalBag. No 2, Rydalmere, N.S.W 2116, Australia Tel : +61-2-9684-7777

#### MITSUBISHI ELECTRIC CORPORATION

HEAD OFFICE: 1-8-12, OFFICE TOWER 2, 4F HARUMI CHUO-KU 104-8122, JAPAN  
NAZUKA WORKS: 1-14, 1-15, MINAMI-HIGASHIKU, NAGAZAKI, JAPAN

When exported from Japan, this manual does not require application to the Ministry of Economy, Trade and Industry for service transaction permission.

Specifications subject to change without notice.  
Printed in Japan on recycled paper.