



FX3U-4HSX-ADP
INSTALLATION MANUAL

Manual Number	JY997D16301
Revision	A
Date	May 2005

This manual describes the part names, dimensions, mounting, and specifications of the product. Before use, read this manual and manuals of relevant products fully to acquire proficiency in handling and operating the product. Make sure to learn all the product information, safety information, and precautions. And, store this manual in a safe place so that you can take it out and read it whenever necessary. Always forward it to the end user. Registration The company name and the product name to be described in this manual are the registered trademarks or trademarks of each company. Effective May 2005 Specifications are subject to change without notice. © 2005 Mitsubishi Electric Corporation

Safety Precaution (Read these precautions before use.)

This manual classify the safety precautions into two categories:

⚠ DANGER and ⚠ CAUTION.

DANGER	Indicates that incorrect handling may cause hazardous conditions, resulting in death or severe injury.
CAUTION	Indicates that incorrect handling may cause hazardous conditions, resulting in medium or slight personal injury or physical damage.

Depending on circumstances, procedures indicated by ⚠ CAUTION may also be linked to serious results. In any case, it is important to follow the directions for usage.

Associated Manuals

Manual name	Manual No.	Description
FX3U Series User's Manual - Hardware Edition	JY997D16501 MODEL CODE: 09R516	Explains FX3U Series PLC specification details for I/O, wiring, installation, and maintenance.
FX3U/FX3UC Series Programming Manual - Basic & Applied Instruction Edition	JY997D16601 MODEL CODE: 09R517	Describes PLC programming for basic/applied instructions and devices.

How to obtain manuals

For the necessary product manuals or documents, consult with the Mitsubishi Electric dealer from where you purchase your product.

Applicable Standard

FX3U-4HSX-ADP complies with EC directive (EMC Directive) and UL standards (UL, cUL). Further information can be found in the following manual.

→ Refer to FX3U Series Hardware Manual (Manual No. JY997D18801)

1. Outline

FX3U-4HSX-ADP high-speed input special adapter (hereinafter called high-speed input special adapter) is a special adapter dedicated to FX3U Series PLC. It retrieves pulse signals from a rotary encoder of which the output type is a differential line driver to a high-speed counter or SPD instruction (FNC 56). Up to two units of this high-speed special adapter can be connected to the main unit per system.

→ For system configuration, refer to the FX3U Series User's Manual - Hardware Edition.

1.1 Incorporated Items

Check if the following product and items are included in the package:

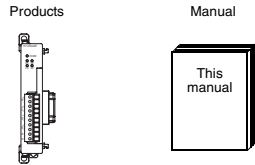

1.2 Input Allocation and Usable High-Speed Counter Number

When the power is turned on, input numbers of the high-speed input special adapters are allocated as shown in the table below in the order of unit position to the main unit. See the table below for usable device number of associated high-speed counter.

→ For details of high-speed counters, refer to the FX3U Series User's Manual - Hardware Edition.

		Second unit		First unit		Main unit
Product	Manual					
Analog special function adapter						
Analog special function adapter						
Analog special function adapter						
High-speed input special adapter						
High-speed output special adapter						
High-speed output special adapter						
High-speed input special adapter						

Expansion board*1

*1 A function extension board is required to use the high-speed I/O special adapter together with a communication/analog special adapter.

→ For system configuration, refer to the FX3U Series User's Manual - Hardware Edition.

	Input number	Associated high-speed counters
First unit	X000 to X002, X006	C235, C236, C237, C241, C242*2, C244, C244(OP), C245*3, C246, C247, C249, C251, C252, C254
Second unit	X003 to X005, X007	C238, C239, C240, C243, C245(OP), C248, C248(OP), C250, C253, C253(OP), C255

*2 Use the terminal of the main unit for reset input if the second high-speed input special adapter is not connected.

*3 Use the terminal of the main unit for start input and reset input if the second high-speed input special adapter is not connected.

Caution

When connecting a high-speed input special adapter, same input numbers are allocated to the main unit and this special adapter. Must use either one of the input terminals. If both input terminals are used, assumed action may not be executed because inputs of the high-speed input special adapter and main unit are operated in an OR relationship to each other.

- Do not use (wire) the input terminal in main unit corresponding to the input number used in the high-speed input special adapter.
- Do not use (wire) the input terminal in high-speed input special adapter corresponding to the input number used in the main unit.

1.3 External Dimensions, Part Names, and Terminal Layout

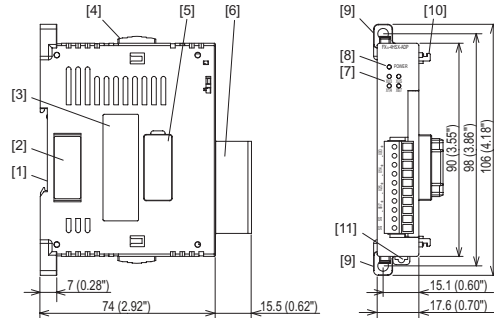

Special adapter connector cover [2] or [5] is removed		Terminal layout of [6]	
Name	Input number	First unit	Second unit
X0/3+	X000+	X003+	
X0/3-	X000-	X003-	
X1/4+	X001+	X004+	
X1/4-	X001-	X004-	
X2/5+	X002+	X005+	
X2/5-	X002-	X005-	
X6/7+	X006+	X007+	
X6/7-	X006-	X007-	
SG	SG	SG	
SG	SG	SG	

- DIN rail mounting groove (DIN rail: DIN46277)
- High-speed I/O special adapter connector cover: Remove this cover for connecting high-speed I/O special adapter on the left side.
- Name plate
- Special adapter slide lock: Used to connect special adapter on left side of this special adapter.
- Special adapter connector cover: Remove this cover for connecting special adapter on the left side.
- Terminal block for inputs (European type): Connects output signals of differential line driver type.
- Input LED (red): Lit when input turns ON (if input turns ON and OFF alternately at high speed, the LED flickers fast).
- POWER LED (green): Lit while power is properly supplied from main unit.
- Direct mounting hole: 2 holes of $\phi 4.5$ (0.18") (mounting screw: M4 screw)
- Special adapter fixing hook
- DIN rail mounting hook
- Special adapter connector: Used to connect the communication special adapter or analog special adapter to this adapter on left side.
- High-speed I/O special adapter connector: Used to connect the high-speed I/O special adapter to this adapter on left side.

2. Installation

The product can be mounted on DIN rail (DIN46227) or mounted directly using screws. For installation/uninstallation and safety precautions, refer to the following manuals:

→ Refer to the FX3U Series User's Manual - Hardware Edition.

INSTALLATION PRECAUTIONS ⚠ DANGER

- Cut off all phases of the power source externally before starting the installation or wiring work, thus avoiding electric shock or damages to the product.

INSTALLATION PRECAUTIONS ⚠ CAUTION

- Use the product in the environment within the general specifications described in PLC main unit manual (Hardware Edition). Never use the product in areas with dust, oily smoke, conductive dusts, corrosive gas (salt air, Cl₂, H₂S, NH₃, SO₂, or NO₂), flammable gas, vibrations or impacts, or expose it to high temperature, condensation, or wind and rain. If the product is used in such a place described above, electrical shock, fire, malfunction, damage, or deterioration may be caused.
- When drilling screw holes or wiring, cutting chips or wire chips should not enter ventilation slits. Such an accident may cause fire, failure or malfunction.
- Do not touch the conductive parts of the product directly, thus avoiding failure or malfunction.
- Fix the special adapter securely to the specified connector. Incorrect connection may cause malfunction.

2.1 Connection to the FX3U Series PLC

- Refer to the procedure 2) for configuring a new system.
- Refer to the procedure 1) for adding product to an existing system.

Procedure

- Turn off the power. Disconnect all the cables connected to the PLC main unit and special adapter. Dismount the main unit and special adapter mounted on DIN rail or mounted directly using screws.
- Install an expansion board to the main unit. For installation of expansion board, refer to the following manual: → Refer to the FX3U Series User's Manual - Hardware Edition

- Remove the high-speed I/O special adapter connector cover (Right fig. A) and the special adapter connector cover (Right fig. B) on the main unit.

In case of connecting this product to a high-speed I/O special adapter as an addition, please replace the 'main unit' in the above description with a 'special adapter' and perform the procedure as indicated. (Please replace the following procedures similarly.)

- Slide the special adapter slide lock (Right fig.C) of the main unit.

- Connect the high-speed I/O special adapter (Right fig.D) to the main unit as shown on the right.
- Slide back the special adapter slide lock (Right fig.C) of the main unit to fix the high-speed I/O special adapter (Right fig.C).

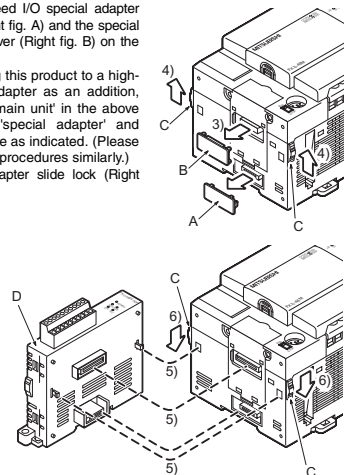

Connection precautions

- Install the expansion board to be used before connecting a special adapter.
- Install an expansion board when using a special adapter other than a high-speed I/O special adapter in combination with a high-speed I/O special adapter.
- Connect all the high-speed I/O special adapters before connecting other special adapters when they are used in combination. Do not connect a high-speed I/O special adapter on the left side of a communication or analog special adapter.

3. Used cables and Tightening Torque on Terminal

For connection example and wiring, refer to the following manual.

→ Refer to FX3U Series User's Manual - Hardware Edition.

WIRING PRECAUTIONS	⚠ DANGER
<ul style="list-style-type: none"> Cut off all phases of power source externally, before installation or wiring work in order to avoid electric shock or damage of product. 	

WIRING PRECAUTIONS	⚠ CAUTION
<ul style="list-style-type: none"> Never let cutting chips and wire chips enter the ventilation slits of this product or PLC when performing wiring. Otherwise, fire, failure or malfunction may occur. Make sure to observe the precautions below in order to prevent any damage to a machine or any accident which might be caused by abnormal data written in the PLC due to the influence of noise: <ol style="list-style-type: none"> Do not lay close or bundle with the main circuit, high-voltage power line, or load line. Otherwise effects of noise or surge induction are likely to take place. Keep a safe distance of more than 100 mm (3.94") from the above when wiring. Ground the shield wire or shield of a shielded cable at one point on the PLC. However, do not ground at the same point as high voltage lines. Observe the following items to wire the lines to the European terminal board. Failing to do so may cause electric shock, short circuit, disconnection, or damage of the product. <ul style="list-style-type: none"> The disposal size of the cable end should follow the dimensions described in this manual. Tighten to a torque should follow the torque described in this manual. Twist the end of strands and make sure there is no loose wires. Do not solder-plate the electric wire ends. Connect only the electric wires of regulation size. Fix the electric wires so that the terminal block and connected parts of electric wires are not directly stressed. 	

1) Wire size
To connect to the desired unit, use a shielded twisted pair cable having a conductor(s) of size AWG22-20.

Type	Wire size
Single-wire	0.3mm ² to 0.5mm ² (AWG22 to 20)
2-wire	2 pieces of 0.3mm ² (AWG22)

3) Termination of cable end
Strip the coating of strand wire and twist the cable core before connecting it, or strip the coating of single wire before connecting it. An alternative connection is to use a ferrule with insulating sleeve.

Manufacturer	Model	Caulking tool
Phoenix Contact Co., Ltd.	AI 0.5-8WH	CRIMPFOX UD6

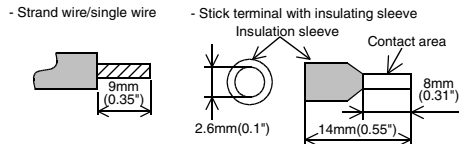

When using a stick terminal with insulating sleeve, choose a wire with proper cable sheath referring to the above outside dimensions, or otherwise, the wire cannot be inserted easily. The tightening torque must be 0.22 to 0.25N-m.

4. Specification

STARTUP AND MAINTENANCE PRECAUTIONS	⚠ CAUTION
<ul style="list-style-type: none"> Do not disassemble or modify the unit. Doing so may cause failure, malfunction or fire. * For repair, contact your local Mitsubishi Electric distributor. Do not drop the product or do not exert strong impact, doing so may cause damage. 	

DISPOSAL PRECAUTIONS	⚠ DANGER
<ul style="list-style-type: none"> Please contact a company certified in the disposal of electronic waste for environmentally safe recycling and disposal of your device. 	

TRANSPORT AND STORAGE PRECAUTIONS	⚠ CAUTION
<ul style="list-style-type: none"> During transportation avoid any impact as the product is a precision instrument. Check the operation of the product after transportation. 	

4.1 Applicable PLC

Model name	Applicability
FX3U Series PLC	Ver. 2.00 (from the first product) and later

The version number can be checked by monitoring D8001 as the last three digits indicate it.

Note
Cannot be connected to FX3UC-32MT-LT.

4.2 General Specification

For the general specification, refer to the manual of the PLC main unit. The items other than the following are equivalent to those of the PLC main unit.

→ Refer to FX3U Series User's Manual - Hardware Edition.

Item	Specification	
Dielectric withstand voltage	500V AC for one minute	Conforming to JEM-1021
Insulation resistance	5MΩ or more by 500V DC megger	Between input terminal of high-speed input special adapter and ground terminal of PLC main unit

4.3 Power Supply Specification

Item	Specification	
Input circuit driving power supply	30mA for 24V DC	Internally supplied from the main unit service power supply.
Adapter driving power supply	30mA for 5V DC	5V DC power is supplied internally from the main unit.

4.4 Performance Specification

Item	Specification	
Input points	4 points (Not counted among the total I/O points of the PLC.)	
Input type	Differential line receiver (Equivalent to AM26C32)	
Maximum input frequency	1 phase 1 input	200kHz
	1 phase 2 inputs	
	2 phase 2 inputs	100kHz
Insulation	External cables of input area are insulated from PLC by photo coupler and transformer.	
Wiring length	Maximum 10m (32' 9")	

*1 The maximum input frequency for the software counter² will be the same as the maximum input frequency of when the main unit counts pulses via the input terminal.

→ For details of input frequency, refer to FX3U Series User's Manual - Hardware Edition.

*2 It also means the hardware counter is operated as a software counter.
→ For conditions of a hardware counter which operates as a software counter, refer to FX3U Series User's Manual - Hardware Edition.

4.5 Connectable Device Caution

The rotary encoder^{*1} connected to the input terminal of FX3U-4HSX-ADP has to fulfill all of the following conditions;

Item	Specifications
Output type	Differential line driver
Output voltage	5V DC or less

*1 If the rotary encoder, which fulfills the above stated conditions, fails to operate, please confirm specifications in advance.

4.6 Internal Circuit of Input Interface

For connection example and wiring, refer to the following manual.

→ Refer to FX3U Series User's Manual - Hardware Edition.

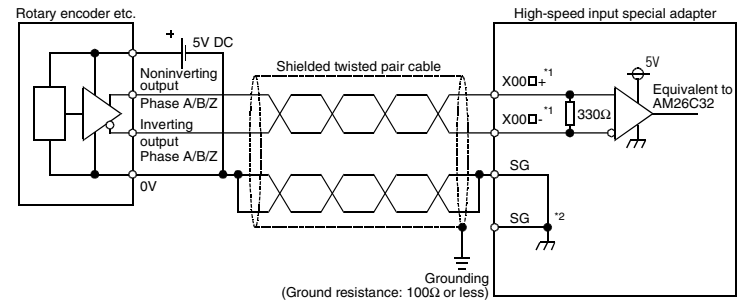

*1 X00□ indicates input number of the high-speed input special adapter.
*2 SG of the first unit and SG of the second unit are insulated from each other.

Grounding

Grounding should be performed as stated below.

- The grounding resistance should be 100Ω or less.
- Independent grounding should be performed for best results. When independent grounding is not performed, perform "shared grounding" of the following figure.

→ For details, refer to the FX3U Series User's Manual - Hardware Edition.

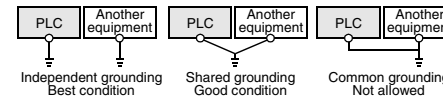

- The grounding wire size should be AWG 14 (2 mm²) or larger.
- The grounding point should be close to the PLC, and all grounding wire should be as short as possible.

This manual confers no industrial property rights or any rights of any other kind, nor does it confer any patent licenses. Mitsubishi Electric Corporation cannot be held responsible for any problems involving industrial property rights which may occur as a result of using the contents noted in this manual.

Warranty

Mitsubishi will not be held liable for damage caused by factors found not to be the cause of Mitsubishi; machine damage or lost profits caused by faults in the Mitsubishi products; damage, secondary damage, accident compensation caused by special factors unpredictable by Mitsubishi; damages to products other than Mitsubishi products; and to other duties.

⚠ For safe use

- This product has been manufactured as a general-purpose part for general industries, and has not been designed or manufactured to be incorporated in a device or system used in purposes related to human life.
- Before using the product for special purposes such as nuclear power, electric power, aerospace, medicine or passenger movement vehicles, consult with Mitsubishi Electric.
- This product has been manufactured under strict quality control. However when installing the product where major accidents or losses could occur if the product fails, install appropriate backup or failsafe functions in the system.

MITSUBISHI PROGRAMMABLE CONTROLLERS MELSEC-F
FX3U-4HSX-ADP
INSTALLATION MANUAL

Manual Number	JY997D16301
Revision	A
Date	May 2005

This manual describes the part names, dimensions, mounting, and specifications of the product. Before use, read this manual and manuals of relevant products fully to acquire proficiency in handling and operating the product. Make sure to learn all the product information, safety information, and precautions. And, store this manual in a safe place so that you can take it out and read it whenever necessary. Always forward it to the end user.

Registration
 The company name and the product name to be described in this manual are the registered trademarks or trademarks of each company.

Effective May 2005
 Specifications are subject to change without notice.
 © 2005 Mitsubishi Electric Corporation

Safety Precaution (Read these precautions before use.)
 This manual classify the safety precautions into two categories:
 ⚠DANGER and ⚠CAUTION.

DANGER Indicates that incorrect handling may cause hazardous conditions, resulting in death or severe injury.

CAUTION Indicates that incorrect handling may cause hazardous conditions, resulting in medium or slight personal injury or physical damage.

Depending on circumstances, procedures indicated by ⚠CAUTION may also be linked to serious results. In any case, it is important to follow the directions for usage.

Associated Manuals

Manual name	Manual No.	Description
FX3U Series User's Manual - Hardware Edition	JY997D16501 MODEL CODE: 09R516	Explains FX3U Series PLC specification details for I/O, wiring, installation, and maintenance.
FX3U/FX3UC Series Programming Manual - Basic & Applied Instruction Edition	JY997D16601 MODEL CODE: 09R517	Describes PLC programming for basic/applied instructions and devices.

How to obtain manuals
 For the necessary product manuals or documents, consult with the Mitsubishi Electric dealer from where you purchase your product.

Applicable Standard

FX3U-4HSX-ADP complies with EC directive (EMC Directive) and UL standards (UL, cUL). Further information can be found in the following manual.
 → Refer to FX3U Series Hardware Manual (Manual No. JY997D18801)

1. Outline

FX3U-4HSX-ADP high-speed input special adapter (hereinafter called high-speed input special adapter) is a special adapter dedicated to FX3U Series PLC. It retrieves pulse signals from a rotary encoder of which the output type is a differential line driver to a high-speed counter or SPD instruction (FNC 56). Up to two units of this high-speed special adapter can be connected to the main unit per system.

→ For system configuration, refer to the FX3U Series User's Manual - Hardware Edition.

1.1 Incorporated Items

Check if the following product and items are included in the package:

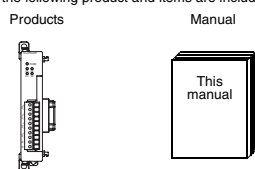

1.2 Input Allocation and Usable High-Speed Counter Number

When the power is turned on, input numbers of the high-speed input special adapters are allocated as shown in the table below in the order of unit position to the main unit. See the table below for usable device number of associated high-speed counter.

→ For details of high-speed counters, refer to the FX3U Series User's Manual - Hardware Edition.

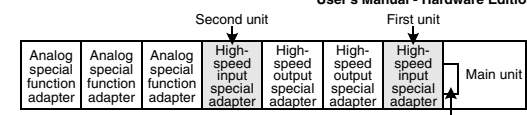

*1 A function extension board is required to use the high-speed I/O special adapter together with a communication/analog special adapter.

→ For system configuration, refer to the FX3U Series User's Manual - Hardware Edition.

	Input number	Associated high-speed counters
First unit	X000 to X002, X006	C235, C236, C237, C241, C242*2, C244, C244(OP), C245*3, C246, C247, C249, C251, C252, C254
Second unit	X003 to X005, X007	C238, C239, C240, C243, C245(OP), C248, C248(OP), C250, C253, C253(OP), C255

*2 Use the terminal of the main unit for reset input if the second high-speed input special adapter is not connected.

*3 Use the terminal of the main unit for start input and reset input if the second high-speed input special adapter is not connected.

Caution

When connecting a high-speed input special adapter, same input numbers are allocated to the main unit and this special adapter. Must use either one of the input terminals. If both input terminals are used, assumed action may not be executed because inputs of the high-speed input special adapter and main unit are operated in an OR relationship to each other.

- Do not use (wire) the input terminal in main unit corresponding to the input number used in the high-speed input special adapter.
- Do not use (wire) the input terminal in high-speed input special adapter corresponding to the input number used in the main unit.

1.3 External Dimensions, Part Names, and Terminal Layout

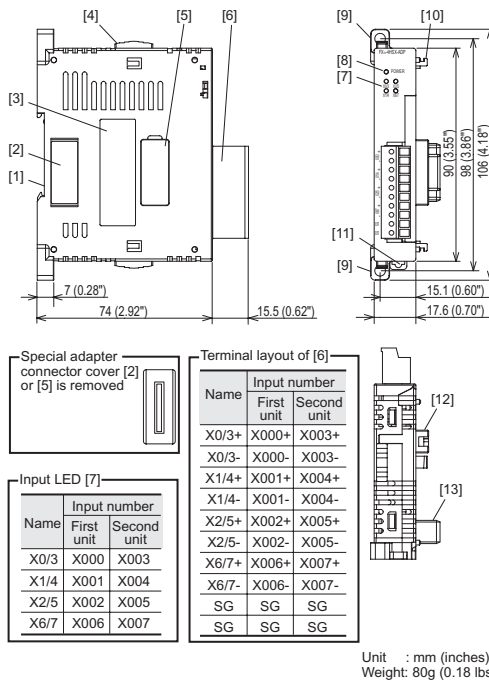

- DIN rail mounting groove (DIN rail: DIN46277)
- High-speed I/O special adapter connector cover: Remove this cover for connecting high-speed I/O special adapter on the left side.
- Name plate
- Special adapter slide lock: Used to connect special adapter on left side of this special adapter.
- Special adapter connector cover: Remove this cover for connecting special adapter on the left side.
- Terminal block for inputs (European type): Connects output signals of differential line driver type.
- Input LED (red): Lit when input turns ON (if input turns ON and OFF alternately at high speed, the LED flickers fast).
- POWER LED (green): Lit while power is properly supplied from main unit.
- Direct mounting hole: 2 holes of $\phi 4.5$ (0.18") (mounting screw: M4 screw)
- Special adapter fixing hook
- DIN rail mounting hook
- Special adapter connector: Used to connect the communication special adapter or analog special adapter to this adapter on left side.
- High-speed I/O special adapter connector: Used to connect the high-speed I/O special adapter to this adapter on left side.

2. Installation

The product can be mounted on DIN rail (DIN46227) or mounted directly using screws. For installation/uninstallation and safety precautions, refer to the following manuals:
 → Refer to the FX3U Series User's Manual - Hardware Edition.

INSTALLATION PRECAUTIONS ⚠DANGER

- Cut off all phases of the power source externally before starting the installation or wiring work, thus avoiding electric shock or damages to the product.

INSTALLATION PRECAUTIONS ⚠CAUTION

- Use the product in the environment within the general specifications described in PLC main unit manual (Hardware Edition). Never use the product in areas with dust, oily smoke, conductive dusts, corrosive gas (salt air, Cl₂, H₂S, NH₃, SO₂, or NO₂), flammable gas, vibrations or impacts, or expose it to high temperature, condensation, or wind and rain.
- If the product is used in such a place described above, electrical shock, fire, malfunction, damage, or deterioration may be caused.
- When drilling screw holes or wiring, cutting chips or wire chips should not enter ventilation slits. Such an accident may cause fire, failure or malfunction.
- Do not touch the conductive parts of the product directly, thus avoiding failure or malfunction.
- Fix the special adapter securely to the specified connector. Incorrect connection may cause malfunction.

2.1 Connection to the FX3U Series PLC

- Refer to the procedure 2) for configuring a new system.
- Refer to the procedure 1) for adding product to an existing system.

Procedure

- Turn off the power. Disconnect all the cables connected to the PLC main unit and special adapter. Dismount the main unit and special adapter mounted on DIN rail or mounted directly using screws.
- Install an expansion board to the main unit. For installation of expansion board, refer to the following manual:
 → Refer to the FX3U Series User's Manual - Hardware Edition
- Remove the high-speed I/O special adapter connector cover (Right fig. A) and the special adapter connector cover (Right fig. B) on the main unit.

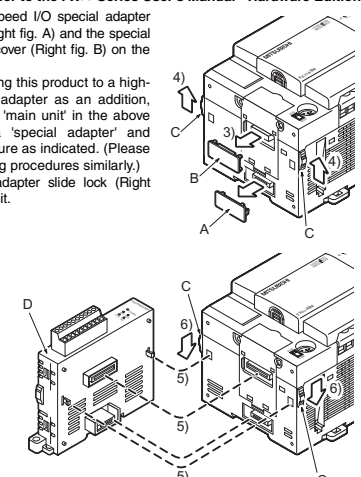

- In case of connecting this product to a high-speed I/O special adapter as an addition, please replace the 'main unit' in the above description with a 'special adapter' and perform the procedure as indicated. (Please replace the following procedures similarly.)
- Slide the special adapter slide lock (Right fig.C) of the main unit.
- Connect the high-speed I/O special adapter (Right fig.D) to the main unit as shown on the right.
- Slide back the special adapter slide lock (Right fig.C) of the main unit to fix the high-speed I/O special adapter (Right fig.C).

Connection precautions

- Install the expansion board to be used before connecting a special adapter.
- Install an expansion board when using a special adapter other than a high-speed I/O special adapter in combination with a high-speed I/O special adapter.
- Connect all the high-speed I/O special adapters before connecting other special adapters when they are used in combination. Do not connect a high-speed I/O special adapter on the left side of a communication or analog special adapter.

3. Used cables and Tightening Torque on Terminal

For connection example and wiring, refer to the following manual.
 → Refer to FX3U Series User's Manual - Hardware Edition.

WIRING PRECAUTIONS ⚠DANGER

- Cut off all phases of power source externally, before installation or wiring work in order to avoid electric shock or damage of product.

WIRING PRECAUTIONS ⚠CAUTION

- Never let cutting chips and wire chips enter the ventilation slits of this product or PLC when performing wiring. Otherwise, fire, failure or malfunction may occur.
- Make sure to observe the precautions below in order to prevent any damage to a machine or any accident which might be caused by abnormal data written in the PLC due to the influence of noise:
 - Do not lay close or bundle with the main circuit, high-voltage power line, or load line. Otherwise effects of noise or surge induction are likely to take place. Keep a safe distance of more than 100 mm (3.94") from the above when wiring.
 - Ground the shield wire or shield of a shielded cable at one point on the PLC. However, do not ground at the same point as high voltage lines.
- Observe the following items to wire the lines to the European terminal board. Failing to do so may cause electric shock, short circuit, disconnection, or damage of the product.
 - The disposal size of the cable end should follow the dimensions described in this manual.
 - Tighten to a torque should follow the torque described in this manual.
 - Twist the end of strands and make sure there is no loose wires.
 - Do not solder-plate the electric wire ends.
 - Connect only the electric wires of regulation size.
 - Fix the electric wires so that the terminal block and connected parts of electric wires are not directly stressed.

1) Wire size
 To connect to the desired unit, use a shielded twisted pair cable having a conductor(s) of size AWG22-20.

2) Applicable cable

Type	Wire size
Single-wire	0.3mm ² to 0.5mm ² (AWG22 to 20)
2-wire	2 pieces of 0.3mm ² (AWG22)

3) Termination of cable end
 Strip the coating of strand wire and twist the cable core before connecting it, or strip the coating of single wire before connecting it. An alternative connection is to use a ferrule with insulating sleeve.

Manufacturer	Model	Caulking tool
Phoenix Contact Co., Ltd.	AI 0.5-8WH	CRIMPFOX UD6

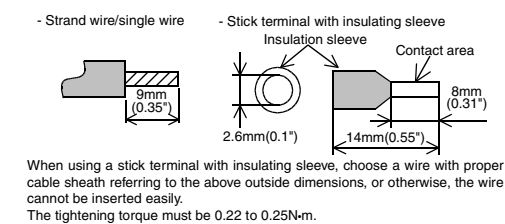

When using a stick terminal with insulating sleeve, choose a wire with proper cable sheath referring to the above outside dimensions, or otherwise, the wire cannot be inserted easily. The tightening torque must be 0.22 to 0.25N·m.

4. Specification

STARTUP AND MAINTENANCE PRECAUTIONS ⚠CAUTION

- Do not disassemble or modify the unit. Doing so may cause failure, malfunction or fire. * For repair, contact your local Mitsubishi Electric distributor.
- Do not drop the product or do not exert strong impact, doing so may cause damage.

DISPOSAL PRECAUTIONS ⚠DANGER

- Please contact a company certified in the disposal of electronic waste for environmentally safe recycling and disposal of your device.

TRANSPORT AND STORAGE PRECAUTIONS ⚠CAUTION

- During transportation avoid any impact as the product is a precision instrument. Check the operation of the product after transportation.

4.1 Applicable PLC

Model name	Applicability
FX3U Series PLC	Ver. 2.00 (from the first product) and later

The version number can be checked by monitoring D8001 as the last three digits indicate it.

Note
 Cannot be connected to FX3UC-32MT-FLT.

4.2 General Specification

For the general specification, refer to the manual of the PLC main unit. The items other than the following are equivalent to those of the PLC main unit.
 → Refer to FX3U Series User's Manual - Hardware Edition.

Item	Specification
Dielectric withstand voltage	500V AC for one minute Conforming to JEM-1021 Between input terminal of high-speed input special adapter and ground terminal of PLC main unit
Insulation resistance	5MΩ or more by 500V DC megger

4.3 Power Supply Specification

Item	Specification
Input circuit driving power supply	30mA for 24V DC Internally supplied from the main unit service power supply.
Adapter driving power supply	30mA for 5V DC 5V DC power is supplied internally from the main unit.

4.4 Performance Specification

Item	Specification	
Input points	4 points (Not counted among the total I/O points of the PLC.)	
Input type	Differential line receiver (Equivalent to AM26C32)	
Maximum input frequency	1 phase 1 input	200kHz High-speed counter operated as hardware counter*1
	1 phase 2 inputs	
	2 phase 2 inputs	
Insulation	External cables of input area are insulated from PLC by photo coupler and transformer.	
Wiring length	Maximum 10m (32' 9")	

*1 The maximum input frequency for the software counter*2 will be the same as the maximum input frequency of when the main unit counts pulses via the input terminal.

→ For details of input frequency, refer to FX3U Series User's Manual - Hardware Edition.

*2 It also means the hardware counter is operated as a software counter.

→ For conditions of a hardware counter which operates as a software counter, refer to FX3U Series User's Manual - Hardware Edition.

4.5 Connectable Device Caution

The rotary encoder*1 connected to the input terminal of FX3U-4HSX-ADP has to fulfill all of the following conditions:

Item	Specifications
Output type	Differential line driver
Output voltage	5V DC or less

*1 If the rotary encoder, which fulfills the above stated conditions, fails to operate, please confirm specifications in advance.

4.6 Internal Circuit of Input Interface

For connection example and wiring, refer to the following manual.
 → Refer to FX3U Series User's Manual - Hardware Edition.

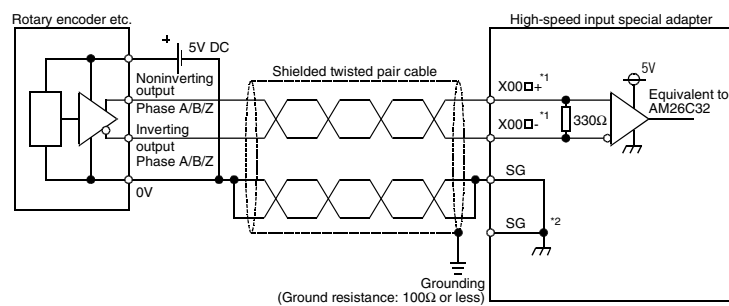

*1 X00□ indicates input number of the high-speed input special adapter.
 *2 SG of the first unit and SG of the second unit are insulated from each other.

Grounding

Grounding should be performed as stated below.

- The grounding resistance should be 100Ω or less.
- Independent grounding should be performed for best results. When independent grounding is not performed, perform "shared grounding" of the following figure.

→ For details, refer to the FX3U Series User's Manual - Hardware Edition.

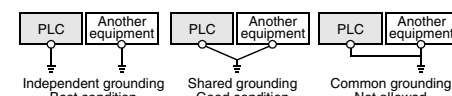

- The grounding wire size should be AWG 14 (2 mm²) or larger.
- The grounding point should be close to the PLC, and all grounding wire should be as short as possible.

This manual confers no industrial property rights or any rights of any other kind, nor does it confer any patent licenses. Mitsubishi Electric Corporation cannot be held responsible for any problems involving industrial property rights which may occur as a result of using the contents noted in this manual.

Warranty
 Mitsubishi will not be held liable for damage caused by factors found not to be the cause of Mitsubishi; machine damage or lost profits caused by faults in the Mitsubishi products; damage, secondary damage, accident compensation caused by special factors unpredictable by Mitsubishi; damages to products other than Mitsubishi products; and to other duties.

For safe use

- This product has been manufactured as a general-purpose part for general industries, and has not been designed or manufactured to be incorporated in a device or system used in purposes related to human life.
- Before using the product for special purposes such as nuclear power, electric power, aerospace, medicine or passenger movement vehicles, consult with Mitsubishi Electric.
- This product has been manufactured under strict quality control. However when installing the product where major accidents or losses could occur if the product fails, install appropriate backup or failsafe functions in the system.