

Changes for the Better

 **mitsubishi**
PROGRAMMABLE CONTROLLERS
MELSEC-F

USER'S MANUAL

FX_{0N}-32NT-DP Profibus-DP Interface Unit

FX_{0N}



Foreword

- This manual contains text, diagrams and explanations which will guide the reader in the correct installation and operation of the FX0N-32NT-DP Profibus-DP Interface Unit. It should be read and understood before attempting to install or use the unit.
- Further information can be found in the Hardware Manual of the PLC, Programming Manual of the PLC, MELSOFT GX Configurator-DP Configuration System for Open Networks Software Manual and the manual of the Profibus-DP master units.
- If in doubt at any stage of the installation of FX0N-32NT-DP Profibus-DP Interface Unit always consult a professional electrical engineer who is qualified and trained to the local and national standards which apply to the installation site.
- If in doubt about the operation or use of FX0N-32NT-DP Profibus-DP Interface Unit please consult the nearest Mitsubishi Electric distributor.
- This manual is subject to change without notice.



FX0N-32NT-DP Profibus-DP Interface Unit

User's Manual

Manual number : JY992D61401

Manual revision : E

Date : March 2008

This manual confers no industrial property rights or any rights of any other kind, nor does it confer any patent licenses. Mitsubishi Electric Corporation cannot be held responsible for any problems involving industrial property rights which may occur as a result of using the contents noted in this manual.

Guidelines for the Safety of the User and Protection of the FX0N-32NT-DP Profibus-DP Interface Unit.

This manual provides information for the use of the FX0N-32NT-DP Profibus-DP Interface Unit. The manual has been written to be used by trained and competent personnel. The definition of such a person or persons is as follows:

- a) Any engineer who is responsible for the planning, design and construction of automatic equipment using the product associated with this manual, should be of a competent nature, trained and qualified to the local and national standards required to fulfill that role. These engineers should be fully aware of all aspects of safety with regards to automated equipment.
- b) Any commissioning or service engineer must be of a competent nature, trained and qualified to the local and national standards required to fulfill that job. These engineers should also be trained in the use and maintenance of the completed product. This includes being completely familiar with all associated documentation for said product. All maintenance should be carried out in accordance with established safety practices.
- c) All operators of the completed equipment should be trained to use that product in a safe and coordinated manner in compliance to established safety practices. The operators should also be familiar with documentation which is connected with the actual operation of the completed equipment.

Note : The term 'completed equipment' refers to a third party constructed device which contains or uses the product associated with this manual.

Note's on the Symbols Used in this Manual

At various times through out this manual certain symbols will be used to highlight points of information which are intended to ensure the users personal safety and protect the integrity of equipment. Whenever any of the following symbols are encountered its associated note must be read and understood. Each of the symbols used will now be listed with a brief description of its meaning.

Hardware Warnings



1) Indicates that the identified danger **WILL** cause physical and property damage.



2) Indicates that the identified danger could **POSSIBLY** cause physical and property damage.



3) Indicates a point of further interest or further explanation.

Software Warnings



4) Indicates special care must be taken when using this element of software.



5) Indicates a special point which the user of the associate software element should be aware.



6) Indicates a point of interest or further explanation.

- Under no circumstances will Mitsubishi Electric be liable or responsible for any consequential damage that may arise as a result of the installation or use of this equipment.
- All examples and diagrams shown in this manual are intended only as an aid to understanding the text, not to guarantee operation. Mitsubishi Electric will accept no responsibility for actual use of the product based on these illustrative examples.
- Owing to the very great variety in possible application of this equipment, you must satisfy yourself as to its suitability for your specific application.

Table of Contents

Guideline	iii
1. Introduction.....	1-1
1.1 Features of the 32NT-DP	1-1
1.2 External Dimensions.....	1-2
1.2.1 Pin Configuration of Profibus-DP Connector	1-4
1.3 System Configuration	1-5
1.4 Applicable PLC	1-6
2. Wiring and Mounting	2-1
2.1 Mounting	2-2
2.1.1 Arrangements.....	2-2
2.1.2 Mounting.....	2-2
2.2 Wiring	2-4
2.2.1 EC and EMC Conformity	2-4
2.2.2 Power Supply Wiring	2-5
2.2.3 Profibus-DP Wiring	2-7
2.2.4 Terminating Resistor	2-8
3. Specifications	3-1
3.1 General Specifications.....	3-1
3.2 Power Supply Specifications	3-1
3.3 Performance Specifications	3-2

4. Buffer Memories (BFMs) Allocation.....	4-1
4.1 Buffer Memories (BFM) Lists	4-2
4.2 Received Output Data, Input Data to Send (BFM #0 ~ #19) <Read/Write>	4-3
4.3 Data Exchange Status Bit (BFM #20) <Read Only>	4-4
4.4 Swap Byte Order (BFM #21) <Read/Write>	4-4
4.5 Length of Sent Data (BFM #22), Length of Received Data (BFM #23) <Read Only>	4-4
4.6 Baud Rate (BFM #24) <Read Only>	4-5
4.7 Communication Status (BFM #25) <Read Only>	4-6
4.7.1 Global Control Command.....	4-8
4.8 PROFIBUS Module ID (BFM #26) <Read Only>.....	4-9
4.9 Slave Address (BFM #27) <Read/Write>	4-9
4.10 User Diagnostics (BFM #28) <Read/Write>	4-10
4.11 Error Status (BFM #29) (Read Only)	4-11
4.11.1 General Error (BFM #29 Bit 0)	4-12
4.11.2 External 24V Power Error (BFM #29 Bit 2).....	4-12
4.11.3 Hardware Error (BFM #29 Bit 3).....	4-12
4.11.4 EEPROM Error (BFM #29 Bit 4).....	4-12
4.11.5 FROM/TO Watchdog Timer (BFM #29 Bit 7)	4-13
4.11.6 Configuration Error (BFM #29 Bit 10).....	4-13
4.11.7 Parameter Error (BFM #29 Bit 11)	4-13
4.11.8 Slave Address Change Error (BFM #29 Bit 12).....	4-13
4.12 Model identification code (BFM #30) <read only>	4-14

5. Setting Operation	5-1
5.1 Installing 32NT-DP Parameters in the DP-master	5-1
5.1.1 DP-slave Address Setting in the DP-master.....	5-1
5.1.2 Setting the Number and Format of Input and Output Words in the DP-master	5-2
5.2 Setting Slave Address in the 32NT-DP	5-3
6. Example Program.....	6-1
7. Diagnostics.....	71
7.1 Preliminary Checks.....	71
7.2 LED Check	72
7.3 Check BFM #29 error status of the 32NT-DP	73
Appendix A:	
Further Information Manual List	A-1

1. Introduction

This FX0N-32NT-DP Profibus-DP Interface Unit (called “32NT-DP” hereinafter) can be used as a slave module to connect an FX0N, FX1N, FX2N or FX2NC^{*1} series programmable controllers (called “PLC” hereinafter) to an existing Profibus-DP network.

The 32NT-DP provides an intelligent slave function for decentralized control applications which need to exchange data with Profibus-DP master CPUs (called “DP-master” hereinafter).

*1 When using an FX2NC series PLC, an FX2NC-CNV-IF is required.

1.1 Features of the 32NT-DP

By using the 32NT-DP the PLC can exchange data with any DP-master.

- The default settings allow to send 16 words and to receive 16 words of data in one communication cycle. These values can be adjusted between four word and 20 words of sent and received data.
- The communication between the PLC main unit and the internal buffer memory of 32NT-DP is handled by FROM/TO instructions.
- The 32NT-DP occupies 8 I/O points on the PLC’s expansion bus. The 8 points can be allocated from either inputs or outputs.
- The 32NT-DP can be connected to a Profibus-DP network by a standard 9-pin D-SUB connector and a shielded twisted pair cable complying with EN50170. Optional glassfiber adapters are supported by the 32NT-DP and are available from other vendors.

1.2 External Dimensions

Accessories: GSD Files (FD 1 piece) MASS (Weight): Approx.0.3 kg(0.66lbs)

Dimensions: mm (inches)

Figure 1.1: External Dimensions

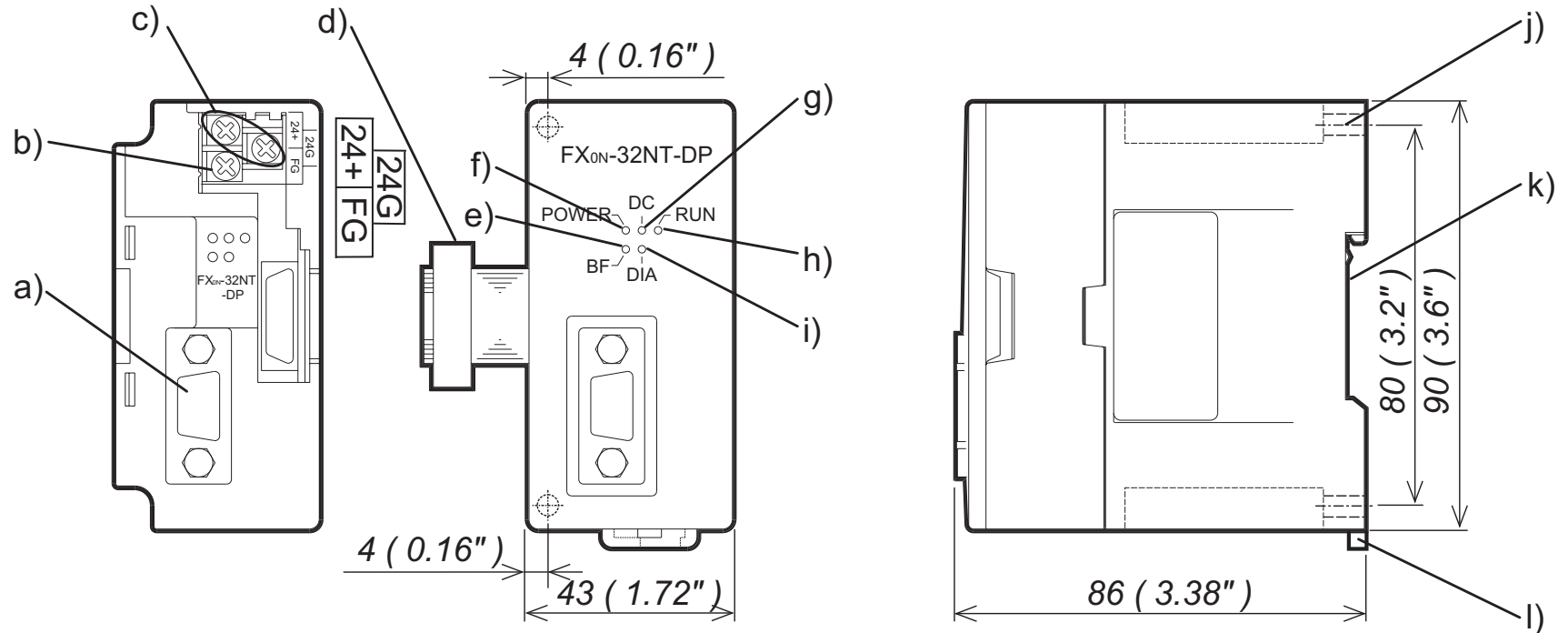

- a) Profibus-DP connector (9-pin D-SUB: #4-40 inc. inch screw thread)
- b) FG terminal (screws terminal: M3.5 (0.14"))
- c) Power supply terminals (screws terminal: M3.5 (0.14"))
- d) Extension cable
- e) BF LED
- f) POWER LED
- g) DC LED
- h) RUN LED
- i) DIA LED
- j) Direct mounting hole (2- ϕ 4.5 (0.18"))
- k) Groove for mounting DIN rail (DIN 46277 <DIN rail width: 35 mm (1.38")>)
- l) Hook for mounting DIN rail

1.2.1 Pin Configuration of Profibus-DP Connector

The connector is a 9-pin D-SUB (#4-40 inc. inch screw thread) type, and the pin configuration is shown below.

Figure 1.2: Pin Layout of Profibus-DP Connector

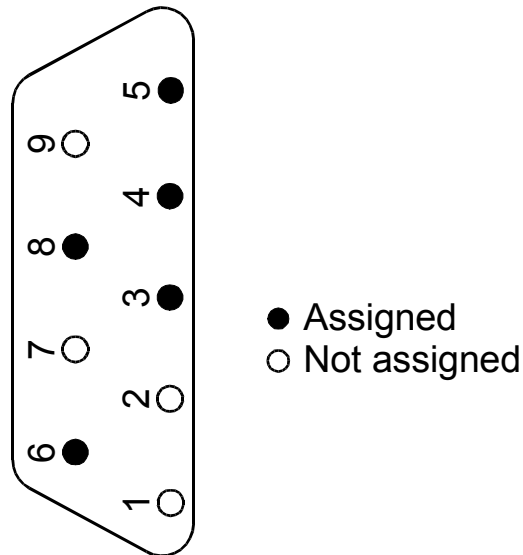
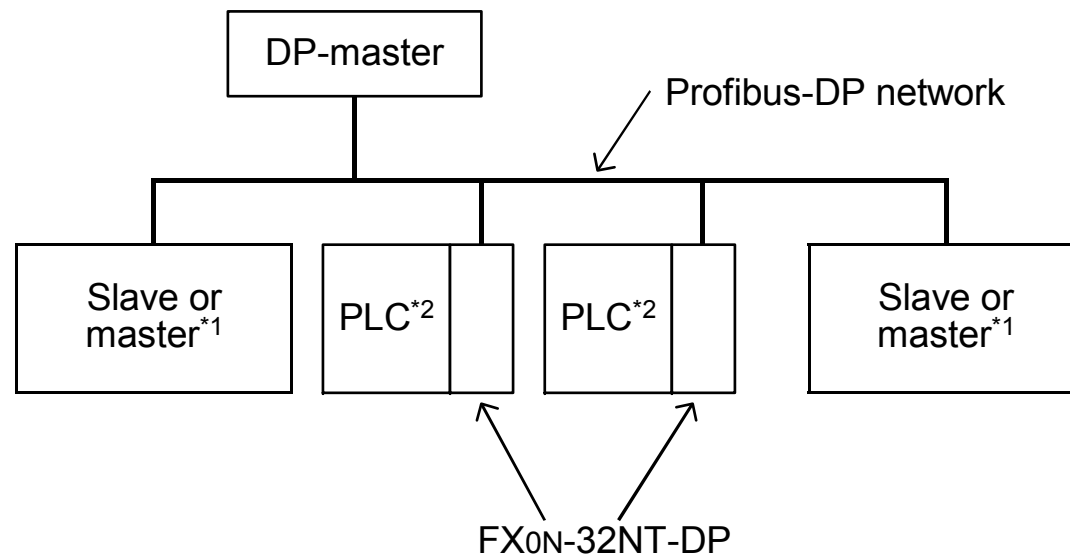

Table 1.1: Profibus-DP Connector Pin Configuration

Pin No.	Signal	Meaning
3	RXD/TXD-P	Receive/Transmit-Data-P
4	RTS	Request to send
5	DGND	Data Ground
6	VP	Voltage-Plus
8	RXD/TXD-N	Receive/Transmit-Data-N
1,2,7,9	NC	Pin not assigned

1.3 System Configuration

Figure 1.3: System Configuration



*1 The units at each end of the Profibus-DP network must have a terminating resistor. This will either be in the master or slave unit or in the DP connector.

*2 PLC is FX0N, FX1N, FX2N or FX2NC series PLC.
When using an FX2NC series PLC, an FX2NC-CNV-IF is required.

1.4 Applicable PLC

For setting up a system, the 32NT-DP can be connected directly to the PLC's extension port or to any other extension unit's right side extension port.

The 32NT-DP occupies 8 points of I/O on the PLC's expansion bus. The 8 points can be allocated from either inputs or outputs. The maximum I/O for the FX_{0N}/FX_{1N} system is 128 I/O. The maximum I/O for the FX_{2N}/FX_{2NC} system is 256 I/O.

Table 1.2: Applicable PLC

PLC Type	Version	Controlled maximum I/O points
FX _{0N} Series	All version	128 points
FX _{1N} Series	All version	128 points
FX _{2N} Series	All version	256 points
FX _{2NC} Series ^{*1}	All version	256 points

*1 When connecting to an FX_{2NC} series PLC, an FX_{2NC}-CNV-IF is required.

2. Wiring and Mounting



Caution

- 1) Do not lay signal cable near to high voltage power cable or house them in the same trunking duct. Effects of noise or surge induction may occur. Keep signal cables a safe distance of more than 100 mm (3.94") from these power cables.
- 2) Ground the shield wire or the shield of a shielded cable at one point on the programmable controller. Do not, however, ground at the same point as high voltage lines.
- 3) The terminal screws of the 32NT-DP are M3.5 (0.14"), therefore the crimp style terminal (see drawing) suitable for use with these screws should be fitted to the cable for wiring.

Figure 2.1: Crimp Terminals

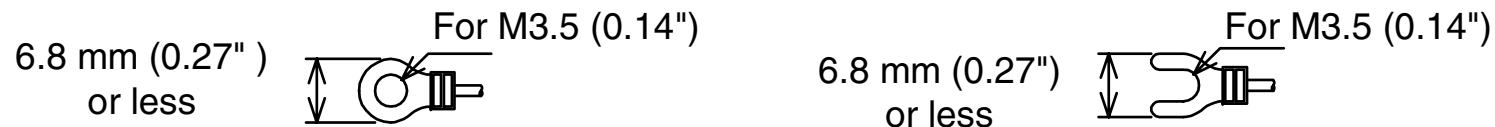

- 4) The terminal tightening torque is 0.5 ~ 0.8 N·m. Tighten securely to avoid malfunction.
- 5) Cut off all phases of power source before installing / removing or performing wiring work on the master in order to avoid electric shock or damage of product.
- 6) Replace the provided terminal cover before supplying power and operating the unit after installation or wiring work, in order to avoid electric shock.

2.1 Mounting

2.1.1 Arrangements

The 32NT-DP connects on the right side of the connected FX0N, FX1N, FX2N or FX2NC^{*1} series main unit or extension unit/block (including special function blocks). For further information of mounting arrangements, refer to the hardware manual of the connected main unit.

*1 When connecting to an FX2NC series PLC, an FX2NC-CNV-IF is required.

2.1.2 Mounting

The mounting method of the 32NT-DP can be DIN rail mounting or direct wall mounting.

1) DIN rail mounting

- a) Align the upper side of the DIN rail mounting groove of the 32NT-DP with a DIN rail*1 (①), and push it on the DIN rail(②). See Figure 2.2.
- b) When removing the 32NT-DP from the DIN rail, the hook for DIN rail is pulled (③), and the 32NT-DP is removed (④). See Figure 2.2.

*1 Uses DIN 46277 <35mm (1.38")>

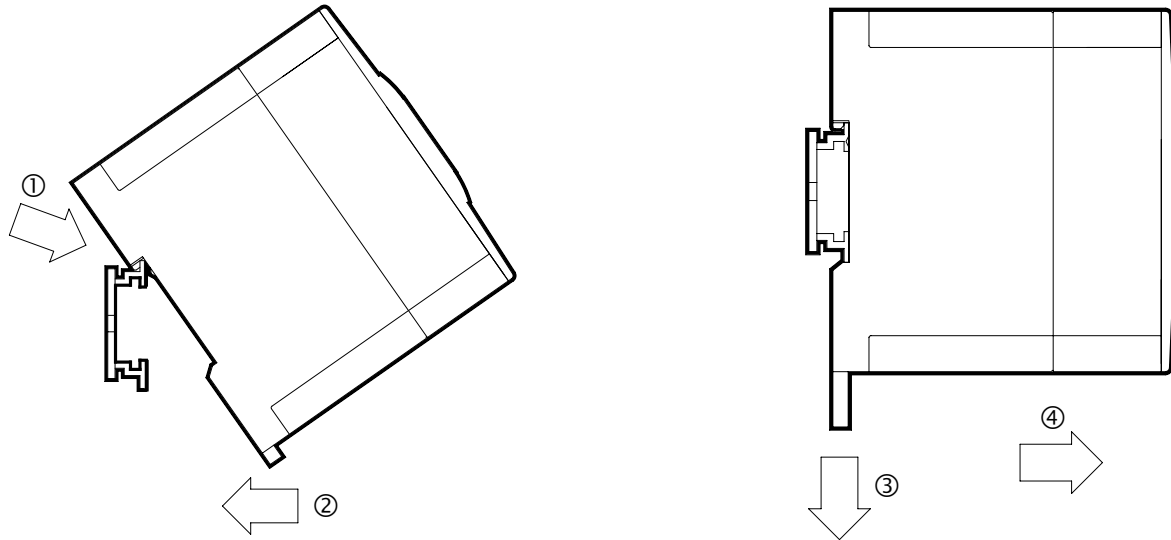
Figure 2.2: Attach to DIN Rail and Remove from DIN Rail

2) Direct mounting to back walls

The 32NT-DP can be mounted with the M4 screw by using the direct mounting hole. However, an interval space between each unit of 1 ~ 2 mm is necessary.

2.2 Wiring

2.2.1 EC and EMC Conformity



Using FX0N

For compliance to EC and EMC regulations it is necessary to fit a ferrite noise filter to the AC power lines of the FX0N main unit or extension unit from which the 32NT-DP 24V power should be taken. (see Figure 2.3.) The filter should be similar to Würth Electronik's part number 742 710 0 B (impedance:4MHz, 80Ω; 25MHz, 139Ω ; 100MHz, 207Ω) and fitted as close to the unit as possible.

It is also necessary to install both the FX0N main unit, extension unit/block and the 32NT-DP slave unit in a metal cabinet.



Using FX1N, FX2N and FX2NC Series PLC

For compliance to EC and EMC regulations it is also necessary to install both the FX1N, FX2N or FX2NC main unit, extension unit/block and the 32NT-DP slave unit in a metal cabinet.

2.2.2 Power Supply Wiring

- 1) When connecting a 32NT-DP to an AC power supply type PLC of the FX0N, FX1N or FX2N Series, the 24V required by the 32NT-DP needs to be supplied from the FX0N, FX1N or FX2N Series PLC. For power supply wiring of the PLC, refer to each series Hardware Manual.

Figure 2.3: FX0N, FX1N and FX2N Series AC Power Supply Type PLC

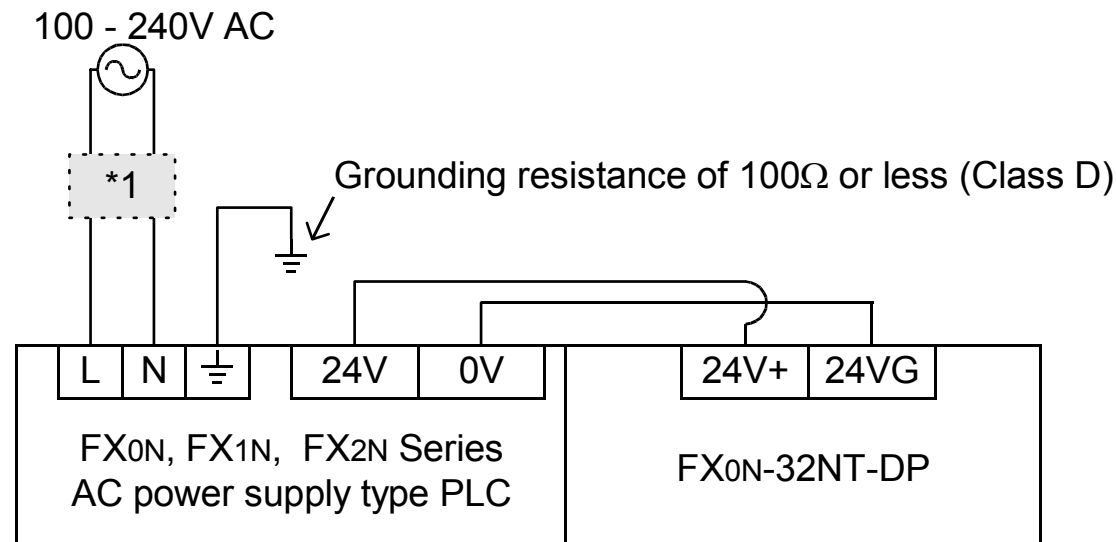

- *1 It is necessary to fit a ferrite noise filter to the AC power lines of the FX0N main unit or extension unit from which the 32NT-DP 24V power should be taken. The filter should be similar to Würth Electronik's part number 742 710 0 B (impedance:4MHz, 80Ω; 25MHz, 139Ω ; 100MHz, 207Ω) and fitted as close to the unit as possible.

- 2) When connecting a 32NT-DP to a DC power supply type PLC of the FX0N, FX1N, FX2N or FX2NC Series, the 24V required by the 32NT-DP needs to be supplied from external power supply same as supplied to the PLC. For power supply wiring of the PLC, refer to each series Hardware Manual.

Figure 2.4: FX0N, FX1N, FX2N and FX2NC Series DC Power Supply Type PLC

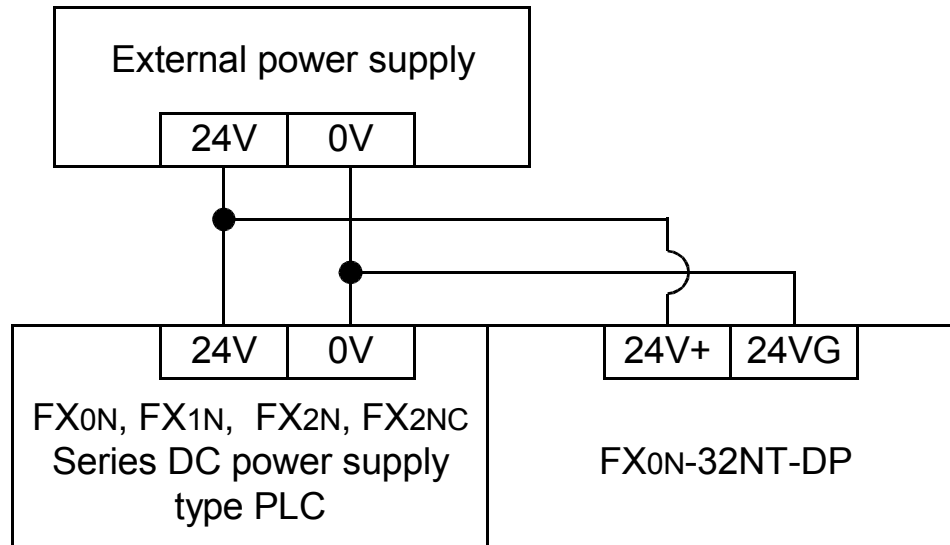

2.2.3 Profibus-DP Wiring

To connect the 32NT-DP to a Profibus-DP network use only the Profibus connectors and shielded twisted-pair cable complying with EN50170. For Profibus connectors see the Profibus connector manual.

Figure 2.5: Wiring

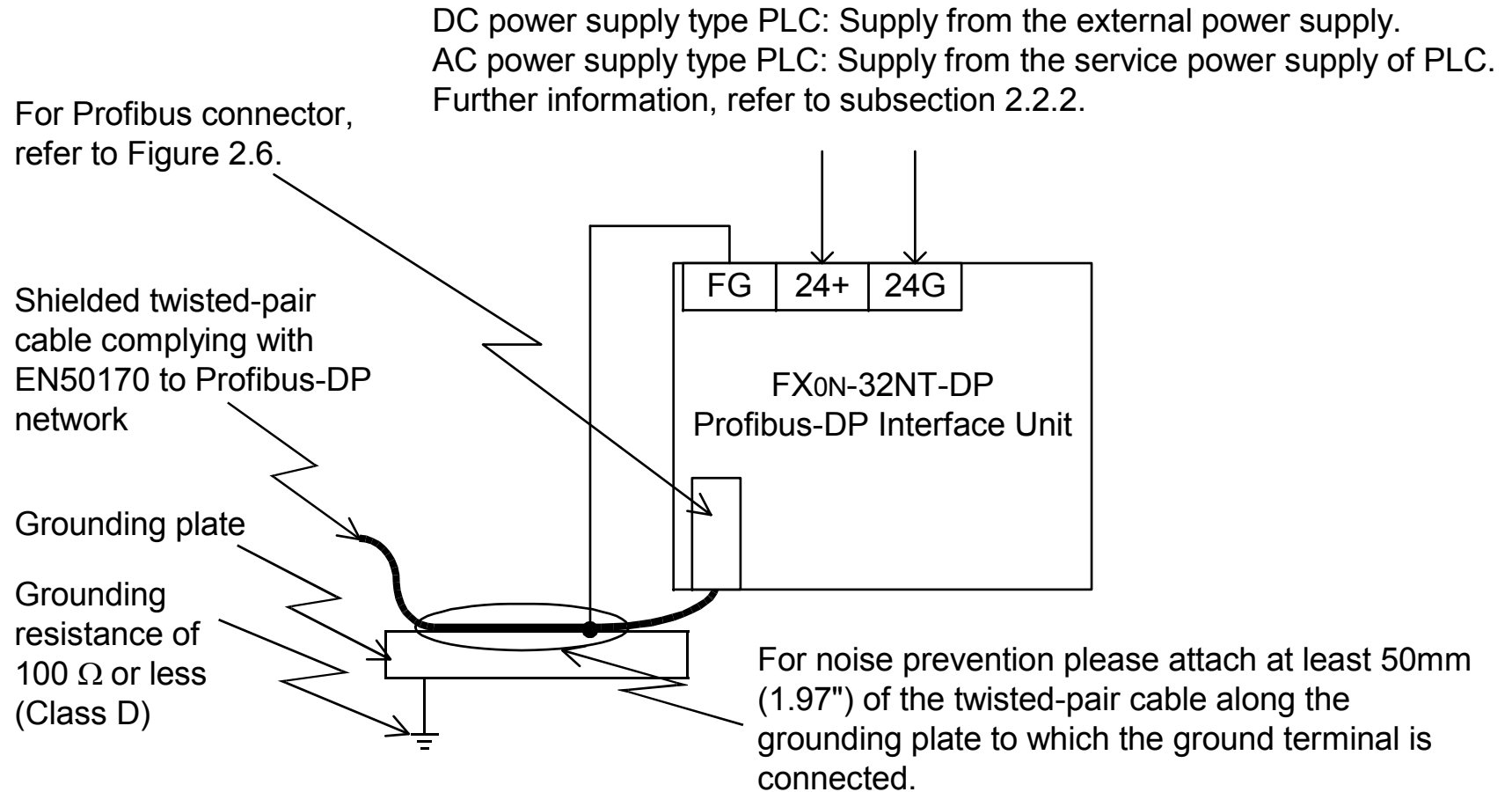
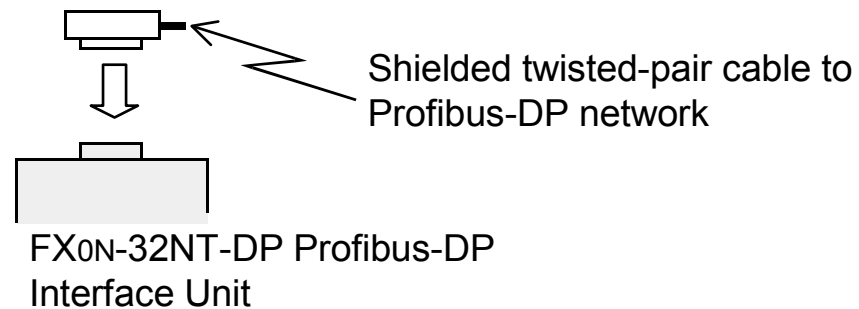

Figure 2.6: Profibus Connector

2.2.4 Terminating Resistor

The units at each end of the Profibus-DP network must have a terminating resistor. This will either be in the master or slave unit or in the Profibus connector.

However, the 32NT-DP does not have a terminating resistance built-in.

3. Specifications

3.1 General Specifications

Table 3.1: General Specifications

Item	Specifications
General specifications (excluding withstand voltage)	Same as those for connecting PLC
Withstand voltage	500V AC for 1 minute (between terminals and earth)

3.2 Power Supply Specifications

Table 3.2: Power Supply Specifications

Item	Specifications
Power supply	24V DC +/- 10%, 20mA (when using a twisted-pair cable) / 60mA (when using a optical glassfiber cable)
Interface power supply	5V DC, 170mA (internal power supply from PLC)

3.3 Performance Specifications

Table 3.3: Performance Specifications

Item	Specifications	
Transmission data	20 words can be sent and received during one bus cycle (default value 16 words). The number of transmitted words can be changed between 4 and 20 words.	
Supported baud rates and bus length	9.6k, 19.2k, 45.45k, 93.75kbps	1,200m
	187.5kbps	1,000m
	500kbps	400m
	1.5Mbps	200m
	3M, 6M, 12Mbps	100m
Applicable PLC	FX0N, FX1N, FX2N, FX2NC ^{*1} Series PLC	
PLC communication	FROM/TO instruction is used to read and write data from/to the 32NT-DP	
LED indicators	POWER LED	ON when 5V DC power is supplied from the PLC (internal power supply).
	DC LED	ON when 24V DC power is supplied from the power supply terminals (external power supply).
	RUN LED	ON when 32NT-DP is exchanging data with Profibus-DP network.
	BF LED	ON when a communication error is detected. (No data exchange)
	DIA LED	ON when notice of diagnostic data is detected.

*1 When using an FX2NC series PLC, an FX2NC-CNV-IF is required.

4. Buffer Memories (BFMs) Allocation



Caution:

- 1) Do not access the buffer memory defined as “Not used” (BFM #31) by FROM/TO instruction. There is a possibility to cause abnormal operation of the 32NT-DP if accessing these buffer memories.
- 2) Do not write to (access by TO instruction) the buffer memory defined as “Read only” (BFM #20, #22 ~ #26, #29, #30) by the programmable controller. It is not possible to operate the 32NT-DP by writing to (accessing by TO instruction) these buffer memories.



Note:

The sending data and receiving data buffers share the same buffer memory addresses (BFM #0 ~ #19) for use with FROM and TO instructions. This means it is not possible to check the buffer memory data using a FROM instruction because this instruction only reads the receive buffer data.

4.1 Buffer Memories (BFM) Lists

Table 4.1: Buffer Memories Lists

BFM No.	Description	
	Read (FROM instruction)	Write (TO instruction)
BFM #0 ~ #19	Received output data (see section 4.2.)	Input data to send (see section 4.2.)
BFM #20	Data exchange status bit (see section 4.3.) <Read only>	
BFM #21	Swap byte order (see section 4.4.) <Read/Write>	
BFM #22	Length of sent data (see section 4.5.) <Read only>	
BFM #23	Length of received data (see section 4.5.) <Read only>	
BFM #24	Baud rate (see section 4.6.) <Read only>	
BFM #25	DP module communication status (see section 4.7.) <Read only>	
BFM #26	PROFIBUS Module ID (PNO-Nr.F032H) see section 4.8. <Read only>	
BFM #27	Slave address (see section 4.9.) <Read/Write>	
BFM #28	User diagnosis (see section 4.10.) <Read/Write>	
BFM #29	Error status (see section 4.11.) <Read only>	
BFM #30	Model identification code (K7020) see section 4.12. <Read only>	
BFM #31	Not used	

4.2 Received Output Data, Input Data to Send (BFM #0 ~ #19) <Read/Write>

When the 32NT-DP is in data exchange mode, the received data from a DP-master is read by the PLC using a FROM instruction. Data is written to the 32NT-DP and sent to the DP-master using a TO instruction.

Figure 4.1: BFM #0 ~ #19

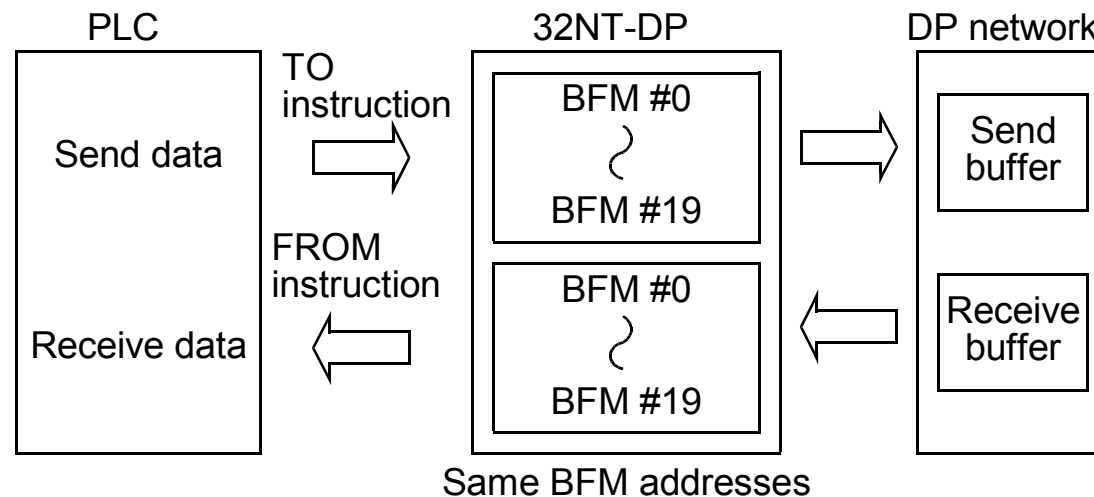

Note:

The sending data and receiving data buffers share the same buffer memory addresses (BFM #0 ~ #19) for use with FROM and TO instructions. This means it is not possible to check the buffer memory data using a FROM instruction because this instruction only reads the receive buffer data.

4.3 Data Exchange Status Bit (BFM #20) <Read Only>

BFM #20 contains a status bit for data exchange. If this value is “1”, the module is in data exchange mode and the received data is valid. If this value is “0”, the module is not in data exchange mode.

4.4 Swap Byte Order (BFM #21) <Read/Write>

Some DP-masters handle lower bytes and higher bytes of a word in reverse order compared to the 32NT-DP module. To enable the module to communicate with these masters, bit 0 of BFM #21 can be set. If bit 0 is “1”, the low order byte and the high order byte of each user data word and of the user specific diagnosis will be swapped. Bit 0 of BFM #21 can also be set or reset by the second user defined parameter byte received from a master. The default value after power up is “0”.

4.5 Length of Sent Data (BFM #22), Length of Received Data (BFM #23) <Read Only>

The values held in these BFMs are copied from the send data length and receive data length settings in the DP-master.

4.6 Baud Rate (BFM #24) <Read Only>

BFM #24 shows the current baud rate of the DP network. The baud rate depends on the DP-master settings. The following table shows the supported baud rates and the value of BFM #24. If the 32NT-DP is in baud search mode, this value frequently changes until the 32NT-DP has found a supported baud rate.

Table 4.2: Baud Rate (BFM #24)

Baud Rate (bps)	BFM #24 Value
9.6k	96E2H
19.2k	19E3H
45.45k	45E3H
93.75k	93E3H
187.5k	18E4H

Baud Rate (bps)	BFM #24 Value
500k	05E5H
1.5M	15E5H
3M	03E6H
6M	06E6H
12M	12E6H



Note:

$96E2 = 96 \times 10^2 = 9,600 = 9.6\text{k}$ baud rate

4.7 Communication Status (BFM #25) <Read Only>

BFM #25 is the 32NT-DP's communication status. According to the status of the 32NT-DP the bits are set and reset as follows.

Table 4.3: Communication Status (BFM #25)

Bit No.	Description	1 (ON)	0 (OFF)
Bit 0	Module on-line/off-line	Module on-line	Module off-line
Bit 1	Not used		
Bit 2	Diagnosis flag	New diagnosis not yet fetched by DP-master	New diagnosis fetched by DP-master
Bit 3	Not used		
Bit 5, Bit 4	DP-state	(b5, b4) = (0, 0): Wait parameter state	
		(b5, b4) = (0, 1): Wait configuration state	
		(b5, b4) = (1, 0): Data exchange state	
		(b5, b4) = (1, 1): Not possible	
Bit 7, Bit 6	DP-watchdog state	(b7, b6) = (0, 0): Baud search state	
		(b7, b6) = (0, 1): Baud control state	
		(b7, b6) = (1, 0): DP control state	
		(b7, b6) = (1, 1): Not possible	
Bit 8	Not used		
Bit 9	Clear data global control	Clear data command received	No clear data command received

Table 4.3: Communication Status (BFM #25)

Bit No.	Description	1 (ON)	0 (OFF)
Bit 10	UNFREEZE global control	UNFREEZE command received	No UNFREEZE command received
Bit 11	FREEZE global control	FREEZE command received	No FREEZE command received
Bit 12	UNSYNC global control	UNSYNC command received	No UNSYNC command received
Bit 13	SYNC global control	SYNC command received	No SYNC command received
Bit 14, Bit 15	Not used		

4.7.1 Global Control Command

The global control commands are processed by the 32NT-DP itself and require no specific measures from the programmable controller user program.

1) Clear data global control

When this command is received, the 32NT-DP clears the output data.

2) UNFREEZE global control

The UNFREEZE command stops freeze control mode. Data written with a TO instruction is immediately sent to the DP-master.

3) FREEZE global control

The DP-master sends a FREEZE control command to a group of DP-slaves to freeze their current input states. Data written with a TO instruction is withheld until the next FREEZE/UNFREEZE command is received.

4) UNSYNC global control

The UNSYNC command stops SYNC control mode. Data sent from the DP-master is immediately transmitted to the BFM to be read using a FROM instruction.

5) SYNC global control

The DP-master sends a SYNC control command to a group of DP-slaves to synchronize their current output states. Data read with a FROM instruction remains constant until the next SYNC/UNSYNC command is received.

4.8 PROFIBUS Module ID (BFM #26) <Read Only>

This buffer memory contains the Profibus module ID number for the 32NT-DP. The ID number is “F032H”.

4.9 Slave Address (BFM #27) <Read/Write>

The 32NT-DP supports setting of the DP-slave address by a Profibus-DP class 2 master via the network and by PLC via a TO instruction. The address is stored in BFM #27. When changing the address using the TO instruction the new address values must be written to BFM #27. The address value is 0 ~ 126. The default value of BFM #27 is set to “126”.

Users should avoid exchanging data with a slave with address #126. An address change is necessary.

4.10 User Diagnostics (BFM #28) <Read/Write>

By writing to BFM #28 the user can transmit high priority diagnostic data to the DP-master.

Data from BFM #28 is transmitted as external diagnostic data to the DP-master where it can be used in the master application. If this diagnosis possibility is used, the user must decide the meaning of the particular bits and the reaction of the master program. This feature could be to map the error bits. An example for use is shown in the following table.

Table 4.4: User Diagnostics (BFM #28)

Bit	Description
Bit 0	User sets for error-1
Bit 1	User sets for error-2
Bit 2	User sets for error-3
⋮	⋮
⋮	⋮
Bit 15	User set for error-16

4.11 Error Status (BFM #29) (Read Only)

BFM #29 indicates error status of the 32NT-DP.

Table 4.5: Error Status (BFM #29)

Bit No.	Description	1 (ON)	0 (OFF)
Bit 0	General error	This bit is ON if b2 ~ b4 are ON	No general error
Bit 1	Not used		
Bit 2	External 24V power error	24V DC power supply failure	Power supply normal
Bit 3	Hardware error	Profibus-DP hardware error	No hardware error detected
Bit 4	EEPROM error	Address data in EEPROM are corrupted	Address data normal
Bit 5, 6	Not used		
Bit 7	FROM / TO watchdog timer (visible only in diagnosis frame)	No FROM / TO instruction received with in 1 second	FROM / TO instruction received
Bit 8, 9	Not used		
Bit 10	Configuration error	Invalid config data received	Config data valid
Bit 11	Parameter error	Invalid parameter data received	Parameter data valid
Bit 12	Slave address change error	New address not valid, no change	New address valid, changed
Bit 13 ~ 15	not used		

4.11.1 General Error (BFM #29 Bit 0)

When a general error occurs (bit 0 = ON) the 32NT-DP tries to send the data of BFM #28 and #29 as a static diagnosis message to the DP-master. In this case data can not be exchanged with the DP-master. After bit 0 returns to OFF, the static diagnosis message is also reset.

4.11.2 External 24V Power Error (BFM #29 Bit 2)

If a 24V DC power supply failure occurs, this bit is ON. If this error occurs, check 24V DC power supply of the 32NT-DP.

4.11.3 Hardware Error (BFM #29 Bit 3)

If a hardware error of the 32NT-DP occurs, this bit is ON. If this error occurs, please contact a service representative.

4.11.4 EEPROM Error (BFM #29 Bit 4)

When address data in EEPROM is corrupted, this bit is ON. If this error occurs, try to set the slave address (BFM #27).

4.11.5 FROM/TO Watchdog Timer (BFM #29 Bit 7)

If no communication requests (FROM / TO) are received by the 32NT-DP within a 1 second time period a watch dog timer error occurs and bit 7 is set ON.

If bit 7 is ON, an external diagnosis message will be sent to the DP-master.



Note:

If no FROM / TO instructions are sent to the 32NT-DP an error will be signaled in the DP-master.

4.11.6 Configuration Error (BFM #29 Bit 10)

When invalid configuration data is received from the DP-master, this bit is ON. When this bit is ON, please check the data format, number of configuration bytes and data consistency setting on the DP-master and make appropriate changes.

4.11.7 Parameter Error (BFM #29 Bit 11)

When invalid parameter data is received from the DP-master, this bit is ON. When this bit is ON, please check parameters on the DP-master.

4.11.8 Slave Address Change Error (BFM #29 Bit 12)

When the new slave value setting for the address of the 32NT-DP is not 0 ~ 126, this bit is ON. In this case the slave address is not changed. Please try again to set a valid slave address (BFM #27).

4.12 Model identification code (BFM #30) <read only>

The identification number for a 32NT-DP is read by using the FROM instruction. The identification number for the 32NT-DP is K7020. By reading this identification number, the user may create built-in checking routines to check whether the physical position of the 32NT-DP matches to that of the software.

5. Setting Operation

For details how to set-up a DP-master please refer to the appropriate DP-master manuals.

5.1 Installing 32NT-DP Parameters in the DP-master

To be able to exchange data with a DP-master the 32NT-DP must receive a valid parameter and configuration data message from the DP-master.

The 32NT-DP parameters are stored in the GSD File (General Station Description File).

This file must be read by the configuration software of the DP-master. Then it is the task of the user to set the DP-slave address and the number and format of the input and output words to the configuration data. After which the configuration can be downloaded to the DP-master.

5.1.1 DP-slave Address Setting in the DP-master

A DP-master of class 2 or more can set a DP-slave address from the DP-master. For details of how to set-up a DP-master please refer to the appropriate DP-master manuals.

5.1.2 Setting the Number and Format of Input and Output Words in the DP-master

The 32NT-DP supports only word data format and word consistency. Combinations of 2 modules and 4 modules can be configured.

The configurations shown in the following table are possible.

Table 5.1: Setting the Number and Format of Input and Output Words

Module	Configuration				
	1	2	3	4	5
1 st	16 words input	16 words input	4 words input	16 words input	4 words input
2 nd	16 words output	16 words output	4 words output	4 words output	16 words output
3 rd	4 words input	-	-	-	-
4 th	4 words output	-	-	-	-

5.2 Setting Slave Address in the 32NT-DP

When setting the DP-slave address from the PLC follow the example program.

Example program

The following is an example of how to set the slave address to “10” of a 32NT-DP connected as block No.0.

Figure 5.1: Example Program

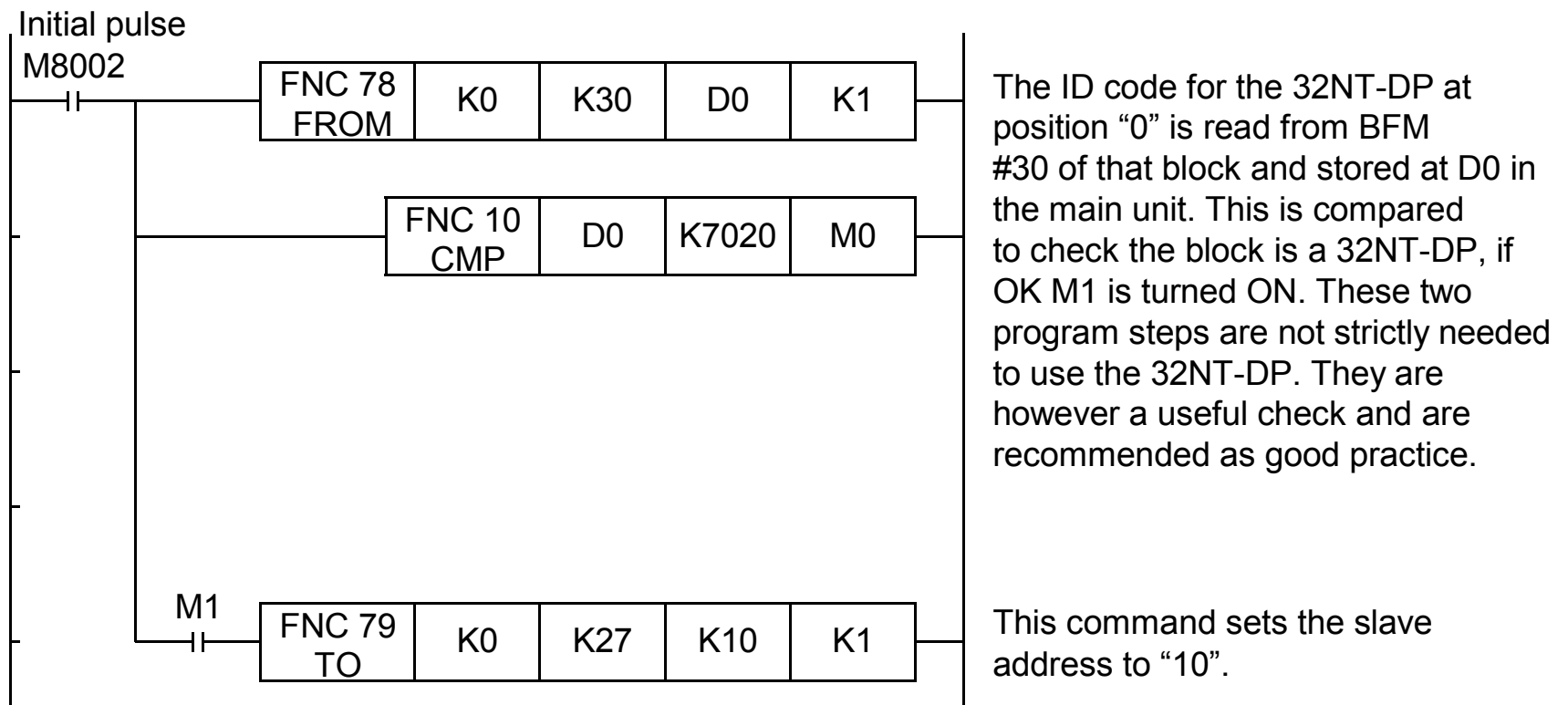

MEMO

6. Example Program

The following is an example program.

Figure 6.1: Example Program

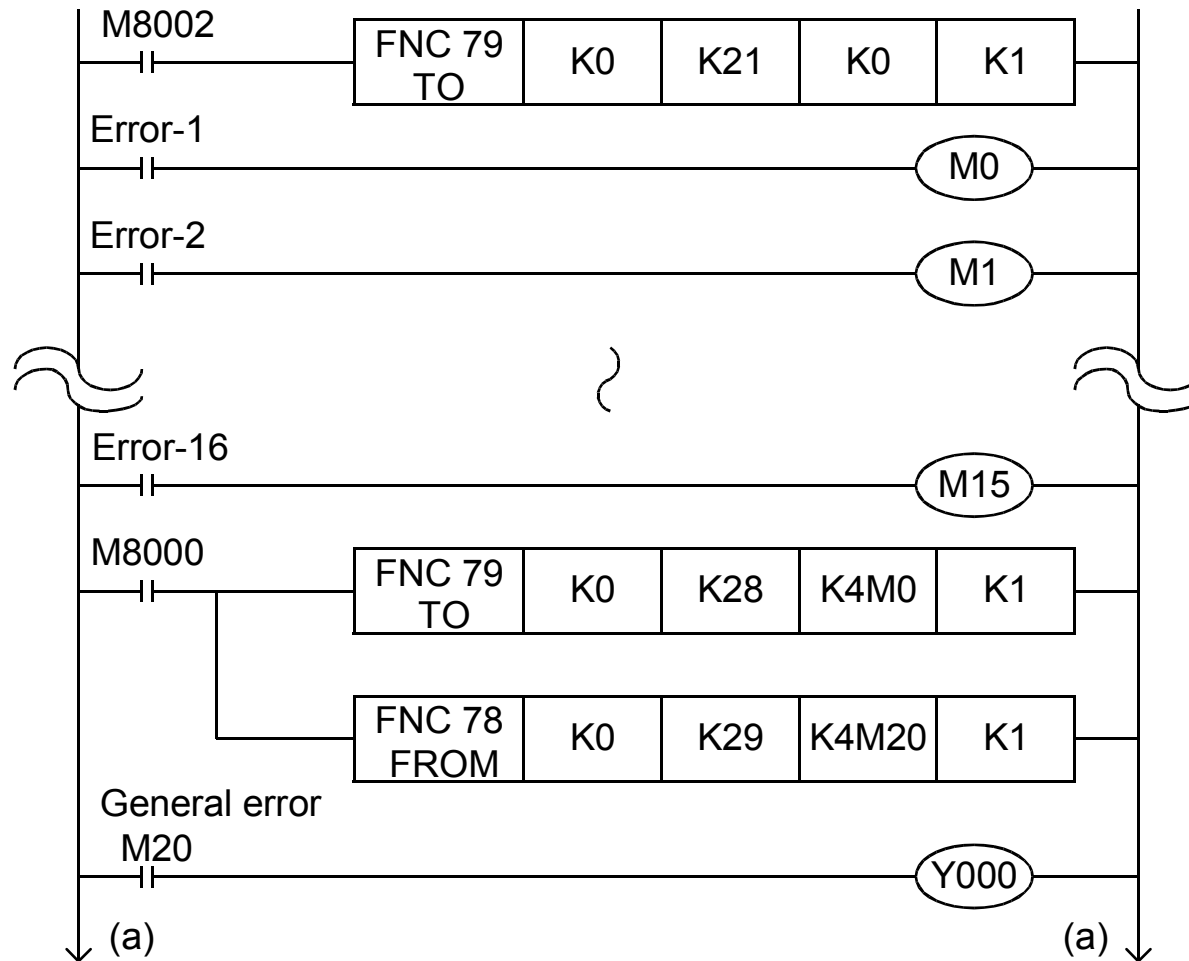

Normal byte order

Send diagnosis to DP-master



Note:
If no FROM / TO instructions are sent to the 32NT-DP an error will be signaled in the DP-master (BFM #29 b7=ON).

Write 32NT-DP error status flag (M0 ~ M15) to the BFM #28.

Read 32NT-DP error status flag to M20 ~ M35.

General Error Flag

Figure 6.1: Example Program

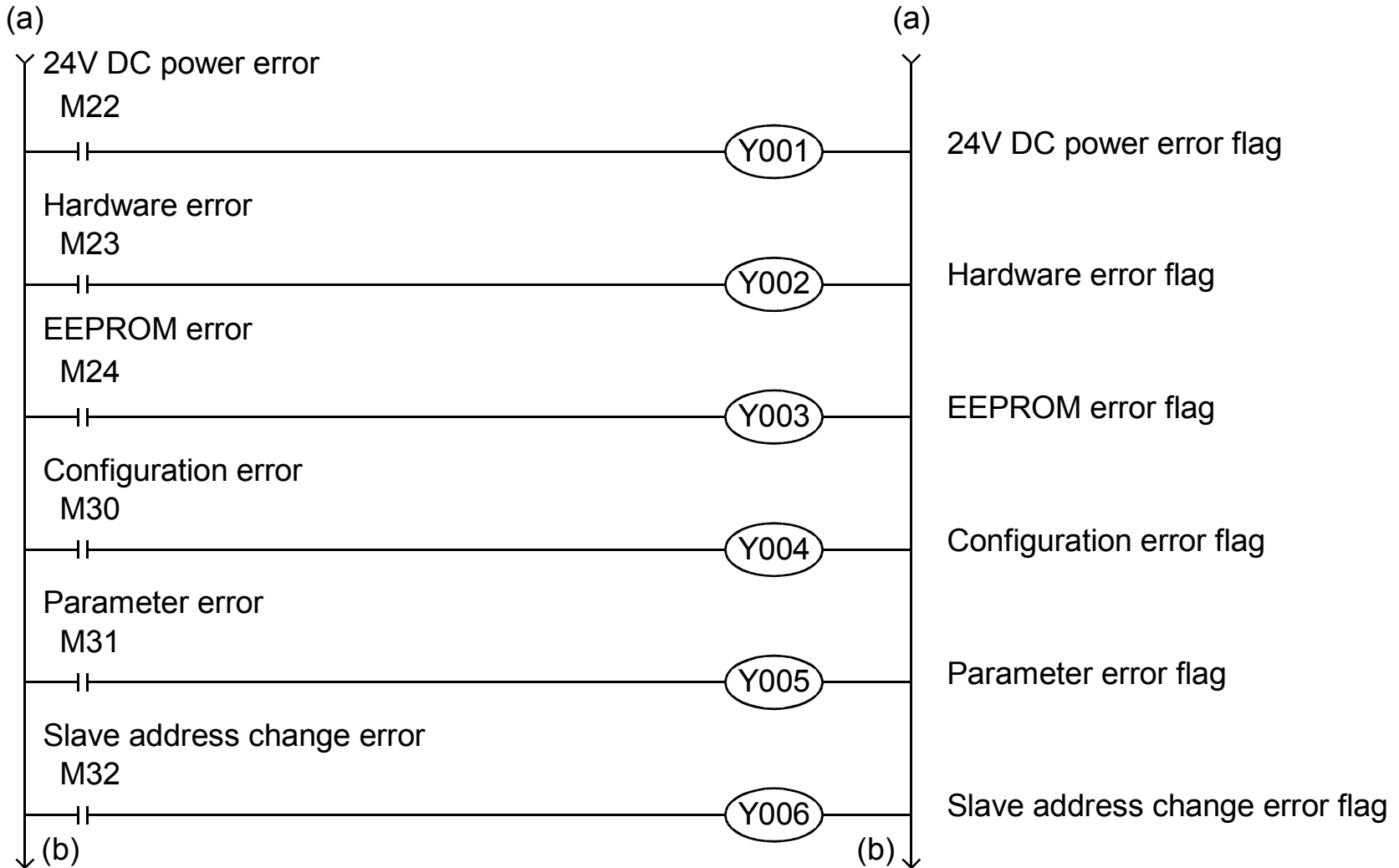
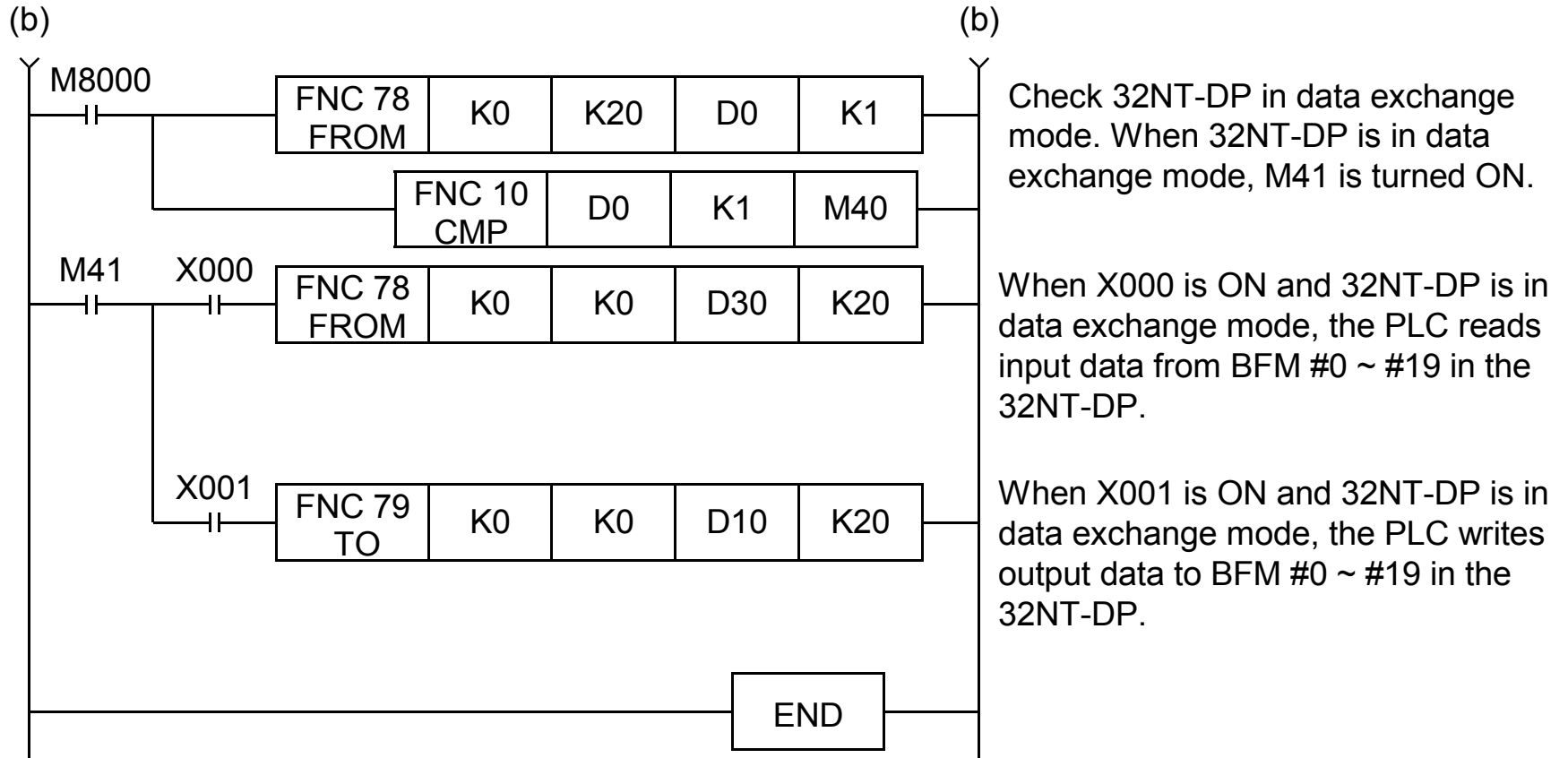

Figure 6.1: Example Program



MEMO

7. Diagnostics

7.1 Preliminary Checks

- 1) Check POWER and DC LED. If this is OFF, please see section 7.2.
- 2) Check that the slave address is the same at the 32NT-DP (BFM #27) and the setting value of the Profibus-DP master configuration tool. If the slave address is not the same, change this address to match at both sides.
- 3) Check that the parameters of 32NT-DP are set in the DP-master.
- 4) Check whether the network wiring and /or extension cables are properly connected on the 32NT-DP.
- 5) Check that the system configuration rules have not been exceeded (i.e. the number of blocks does not exceed 8 and the total system I/O is equal or less than 128^{*1} I/O).

*1 FX0N, FX1N Series PLC is 128 I/O points.
FX2N, FX2NC Series PLC is 256 I/O points.

- 6) Put the PLC into RUN.

7.2 LED Check

Check the status of the LED's for the 32NT-DP as follows.

1) DC LED check

Table 7.1: DC LED Check

Status	Description
Lit	32NT-DP is OK, 24V DC power source is OK.
Otherwise	Possible 24V DC power failure, if OK then possible 32NT-DP failure.

2) POWER LED check

Table 7.2: POWER LED Check

Status	Description
Lit	The extension cable is properly connected.
Otherwise	Check the connection of the 32NT-DP extension cable to the PLC.

3) RUN, BF and DIA LED check

●: ON ○: OFF

Table 7.3: RUN, BF and DIA LED Check

RUN LED	BF LED	DIA LED	Status	Action
●	○	○	Normal operation	
○	●	○	No communication/ baud search mode	Point a)
●	○	●	External diagnostic error	Point b)
○	●	●	Static diagnostic error	Point c)

- a) Check BFM #24. If BFM #24 does not show a stable baud rate (i.e. always changing) then check DP-network cables. Check BFM #29. If BFM #29 is not “0” refer to section 4.11 for details.
- b) Check BFM #28. (User error flags)
- c) Check b0 ~ b7 of #29. If b0 ~ b7 of BFM #29 is not “0”, refer to section 4.11 for details.

7.3 Check BFM #29 error status of the 32NT-DP

If BFM #29 is not “0”, refer to section 4.11 for details.

MEMO

Appendix A: Further Information Manual List

Table A-1: Further Information Manual List

Manual name	Manual No.	Description
FX _{2N} Series PLC Hardware Manual	JY992D66301	Describes FX _{2N} Series PLC specification details for I/O, wiring, installation and maintenance.
FX _{2NC} (DSS/DS) Series PLC Hardware Manual	JY992D76401	Describes FX _{2NC} (DSS/DS) Series PLC specification details for I/O, wiring, installation and maintenance.
FX _{2NC} (D/UL) Series PLC Hardware Manual	JY992D87201	Describes FX _{2NC} (D/UL) Series PLC specification details for I/O, wiring, installation and maintenance.
FX _{1N} Series PLC Hardware Manual	JY992D89301	Describes FX _{1N} Series PLC specification details for I/O, wiring, installation and maintenance.
FX ₀ /FX _{0N} Series PLC Hardware Manual	JY992D47501	Describes FX ₀ and FX _{0N} Series PLC specification details for I/O, wiring, installation and maintenance.
FX Series PLC Programming Manual II	JY992D88101	Describes FX _{1S} , FX _{1N} , FX _{2N} and FX _{2NC} Series PLC programming for basic/ applied instructions and devices.
FX Series PLC Programming Manual	JY992D48301	Describes FX ₀ , FX _{0S} , FX _{0N} , FX and FX _{2C} Series PLC programming for basic/ applied instructions and devices.
GX Configurator-DP Configuration System for Open Networks Software Manual	-	Describes operation details of GX Configurator-DP Configuration System for Networks Software.

MEMO

USER'S MANUAL

FX₀N-32NT-DP Profibus-DP Interface Unit



HEAD OFFICE: TOKYO BUILDING, 2-7-3 MARUNOUCHI, CHIYODA-KU, TOKYO 100-8310, JAPAN
HIMEJI WORKS: 840, CHIYODA CHO, HIMEJI, JAPAN

JY992D61401E
(MEE)

Effective Mar. 2008
Specification are subject
to change without notice.