

MITSUBISHI

A/D Converter module type A1S64AD

User's Manual (Hardware)

Thank you for buying the Mitsubishi general-purpose programmable logic controller MELSEC-A Series

Prior to use, please read both this manual and detailed manual thoroughly and familiarize yourself with the product.

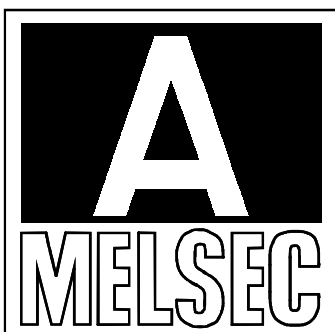

MODEL	A1S64AD(H/W)-U-E
MODEL CODE	13JE46
IB(NA)-66485-C(0210)MDOC	

● SAFETY PRECAUTIONS ●

(Read these precautions before using.)

When using Mitsubishi equipment, thoroughly read this manual and the associated manuals introduced in this manual. Also pay careful attention to safety and handle the module properly.

These precautions apply only to Mitsubishi equipment. Refer to the CPU module user's manual for a description of the PLC system safety precautions. These ●SAFETY PRECAUTIONS● classify the safety precautions into two categories: "DANGER" and "CAUTION".



DANGER

Procedures which may lead to a dangerous condition and cause death or serious injury if not carried out properly.



CAUTION

Procedures which may lead to a dangerous condition and cause superficial to medium injury, or physical damage only, if not carried out properly.

Depending on circumstances, procedures indicated by  CAUTION may also be linked to serious results.

In any case, it is important to follow the directions for usage.

Store this manual in a safe place so that you can take it out and read it whenever necessary. Always forward it to the end user.

[PRECAUTIONS FOR DESIGN]

CAUTION

- Do not bunch the control wires or communication cables with the main circuit or power wires, or install them close to each other. They should be installed 100mm (3.9inch) or more from each other. Not doing so could result in noise that may cause malfunction.

[INSTALLATION PRECAUTIONS]

CAUTION

- Use the PC in an environment that meets the general specifications contained in this manual. Using this PC in an environment outside the range of the general specifications could result in electric shock, fire, erroneous operation, and damage to or deterioration of the product.
- Install so that the pegs on the bottom of the module fit securely into the base unit peg holes. The module fixing screws must be tightened by the specified torque. Not installing the module correctly or tightening the screws to the terminal base could result in erroneous operation, damage, or pieces of the product falling.

[WIRING PRECAUTIONS]

CAUTION

- If there are high levels of noise, ground the AG terminal and FG terminal with Class D grounding (Class 3 grounding) or higher dedicated for the PLC. Failure to observe this could lead to malfunctioning.
- When wiring in the PLC, be sure that it is done correctly by checking the product's rated voltage and the terminal layout. Connecting a power supply that is different from the rating or incorrectly wiring the product could result in fire or damage.
- Tighten terminal screws to the specified torque.
If a terminal screw is not tightened to the specified torque, it the module may fall out, short circuit, or malfunction.
If a terminal screw is tightened excessively, exceeding the specified torque, the module may fall out, short circuit, or malfunction due to breakage of the screw or the module.
- Be careful not to let foreign matters such as sawdust or wire chips get inside the module. These may cause fires, failure or malfunction.

[STARTUP/MAINTENANCE PRECAUTIONS]

DANGER

- When power is on, do not touch the terminals.
Doing so can cause an electric shock or malfunction.
- Before starting cleaning or terminal screw retightening, always switch off the power externally in all phases.
Not switching the power off in all phases can cause a module failure or malfunction.

CAUTION

- Never disassemble or modify the module.
Failure to observe this could lead to trouble, malfunctioning, injuries or fires.
- Always turn the power OFF before installing or removing the module. Failure to observe this could lead to module faults or malfunctioning.

[PRECAUTIONS FOR DISPOSAL]

CAUTION

- Dispose of this product as industrial waste.

About the Manuals

The following manuals are related to this product.
Refer to the following table, and procure these manuals as necessary.

Detailed Manual

Manual name	Manual No. (Model code)
A/D converter module type A1S64AD User' s Manual	IB-66336

1. Outline

This manual explains the specifications and names of each part of the A1S64AD type analog/digital converter (hereinafter, A1S64AD) used in combination with the MELSEC-A Series PLC CPU module (hereinafter PLC CPU).

2. Performance Specifications

The performance specifications of the A1S64AD are shown below.

Item	Specifications			
Analog input	Voltage: -10 to 0 to +10VDC (input resistance 1M Ω) Current: -20 to 0 to +20mA (input resistance 250 Ω)			Select with the input terminals.
Digital input	16-bit coded binary	-4096 to +4095 when set to 1/4000 -8192 to +8191 when set to 1/8000 -12288 to +12287 when set to 1/12000		
Input/output characteristics *1	Analog input	Digital output value (At 5V/20mA gain, 0V/90mA offset)		
		1/4000	1/8000	1/12000
	+10V	+4000	+8000	+12000
	+5V or +20mA 0V or 0mA	+2000 0	+4000 0	+ 6000 0
	-5V or -20mA -10V	-2000 -4000	-4000 -8000	-6000 -12000
Maximum resolution		1/4000	1/8000	1/12000
	Voltage input Current input	2.5mV 10 μ A	1.25mV 5 μ A	0.83mV 3.33 μ A
General accuracy *2	Within \pm 1%	\pm 40	\pm 80	\pm 120
Maximum conversion speed	20ms/channel			
Maximum absolute input	Voltage \pm 15V Current \pm 30mA			
No. of analog input points	4 channels/module			
Isolation specifications	Specific isolated area	Isolation method	Dielectric withstand voltage	Insulation resistance
	Between input terminal and PLC power supply	Photocoupler isolation	500V AC for 1 minute	5M Ω or more (measured with a 500V DC insulation resistance tester)
	Between channels	Not isolated	-	-

Item	Specifications
No. of occupied input/output points	Special 32 points
Connection terminal	20-point terminal block
External power supply	Not required
Applicable wire size	0.75 to 1.5mm ²
Applicable crimp terminal	1.25-3, 1.25-YS3, V1.25-3, V1.25-YS3A
Internal current consumption (5VDC)	0.4A
Weight	0.25kg

*1: The gain is set to 5V and the offset to 0V as the default.

*2: This is the accuracy in respect to the maximum digital output value. The maximum digital value is the maximum value of the selected resolution. It is the same for either a current input or voltage input.

Point
The range of the analog input at the which maximum resolution and general accuracy can be tolerated is as follows. Voltage -10 to 0 to +10V Current -20 to 0 to +20mA





Refer to the User's Manual for the PLC CPU in use for details on the general specifications.

3. Names and Settings of Each Part

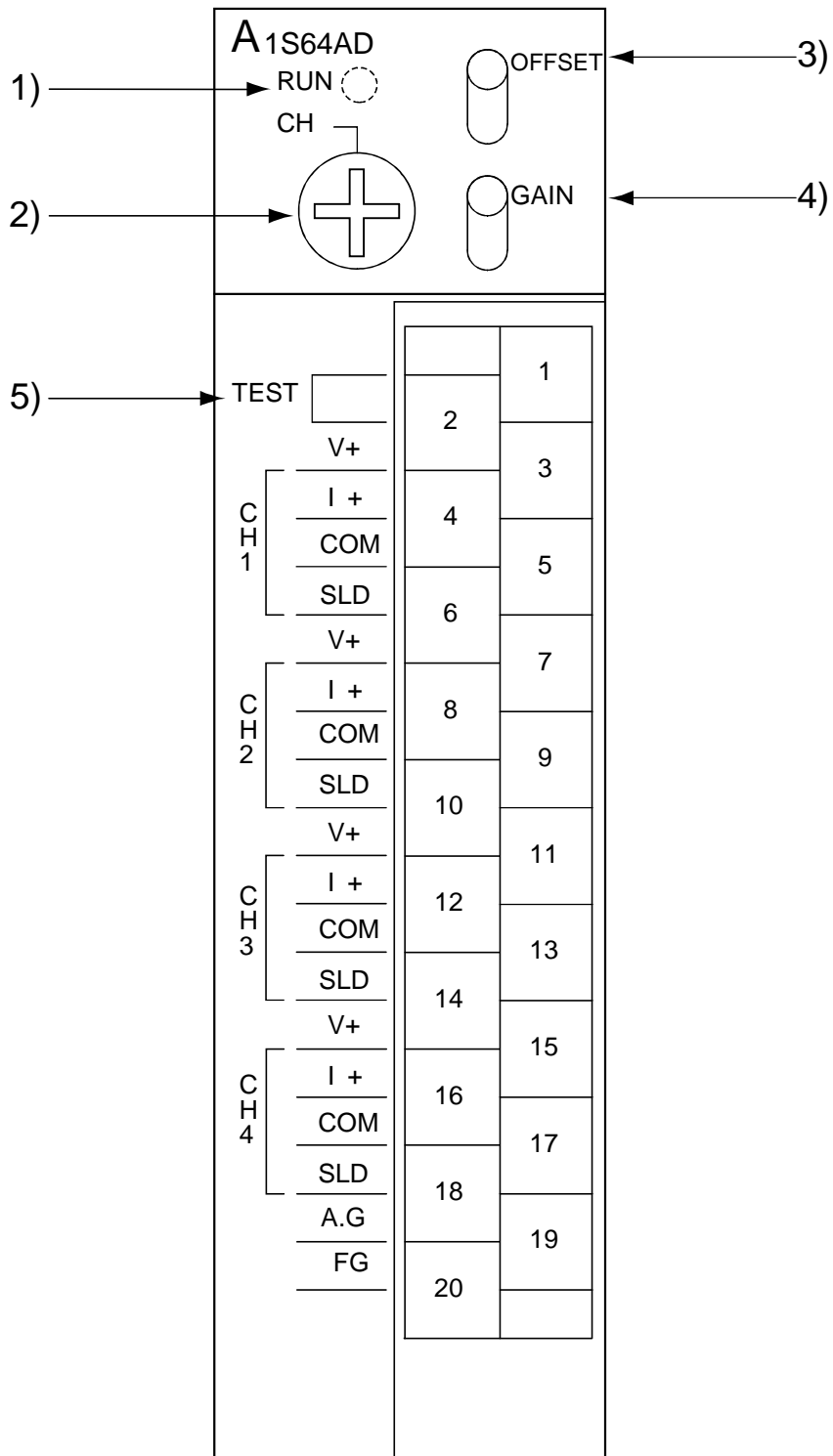
3.1 Names of each part

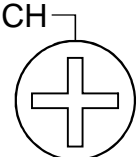
The names of each A1S64AD part are shown below.



No.	Name	Details
1)	RUN LED 	The operation state of the A1S64AD is indicated. • Normal mode ON : In normal operation Flickering: Write data error has occurred. OFF : 5V power OFF or watch dog timer error • Test mode ON : OFF SET switch or GAIN switch is ON OFF : OFF SET switch and GAIN switch are both OFF
2)	CHANNEL selection switch 	The channel for adjusting the offset and the gain is selected. (Channels other than 1 to 4 have no process.)
3)	OFF SET switch 	By setting the switch to the OFF SET side, the analog input value at that time will be saved by the A1S64AD as the offset value.
4)	GAIN switch 	By setting the switch to the GAIN side, the analog input value at that time will be saved by the A1S64AD as the gain value.
5)	Test mode terminal 	Short-circuit across terminals 1 and 2 when setting the offset or gain.

3.2 Setting the offset and gain

Follow the procedure below to change the input/output conversion characteristics.

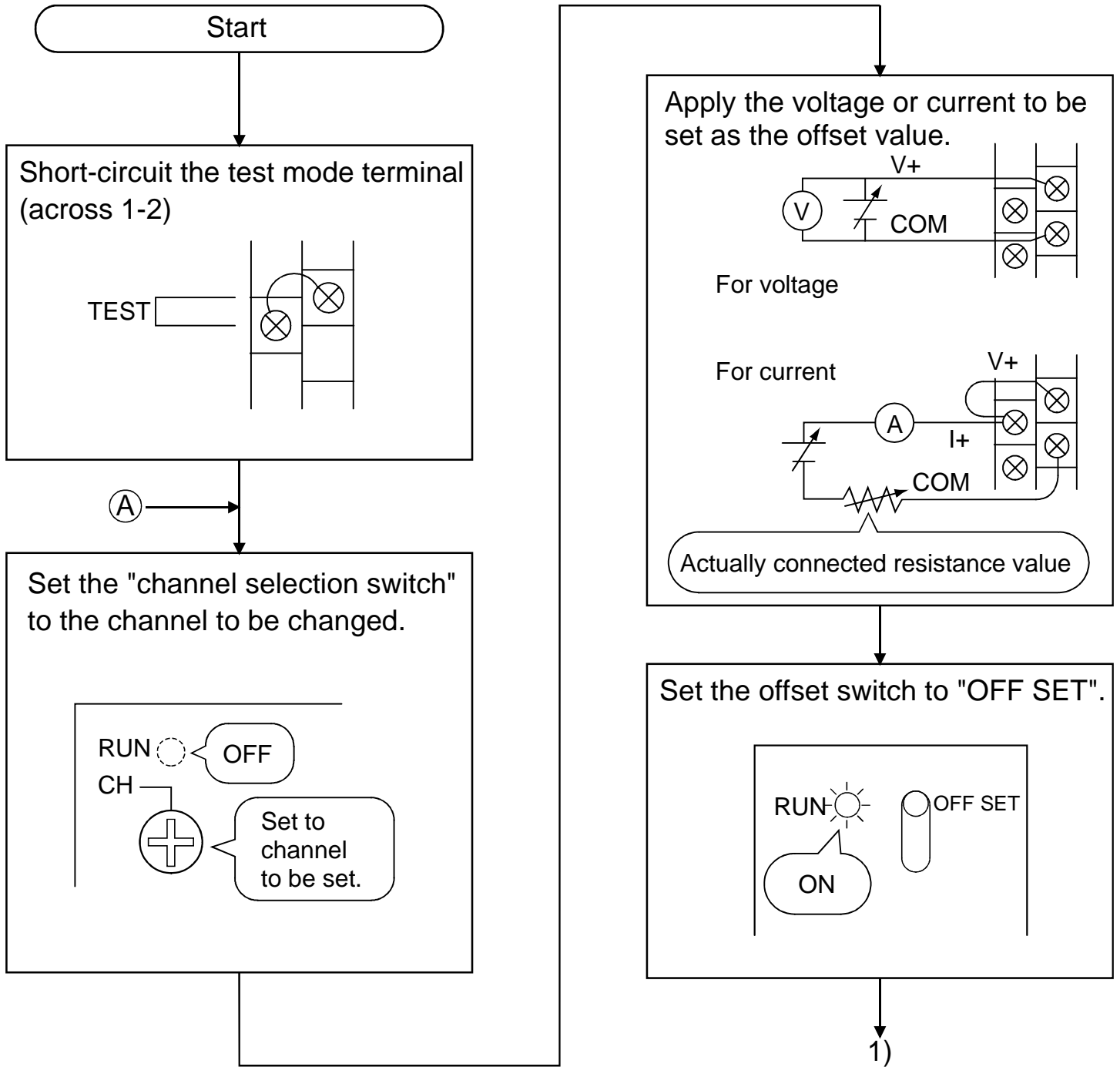

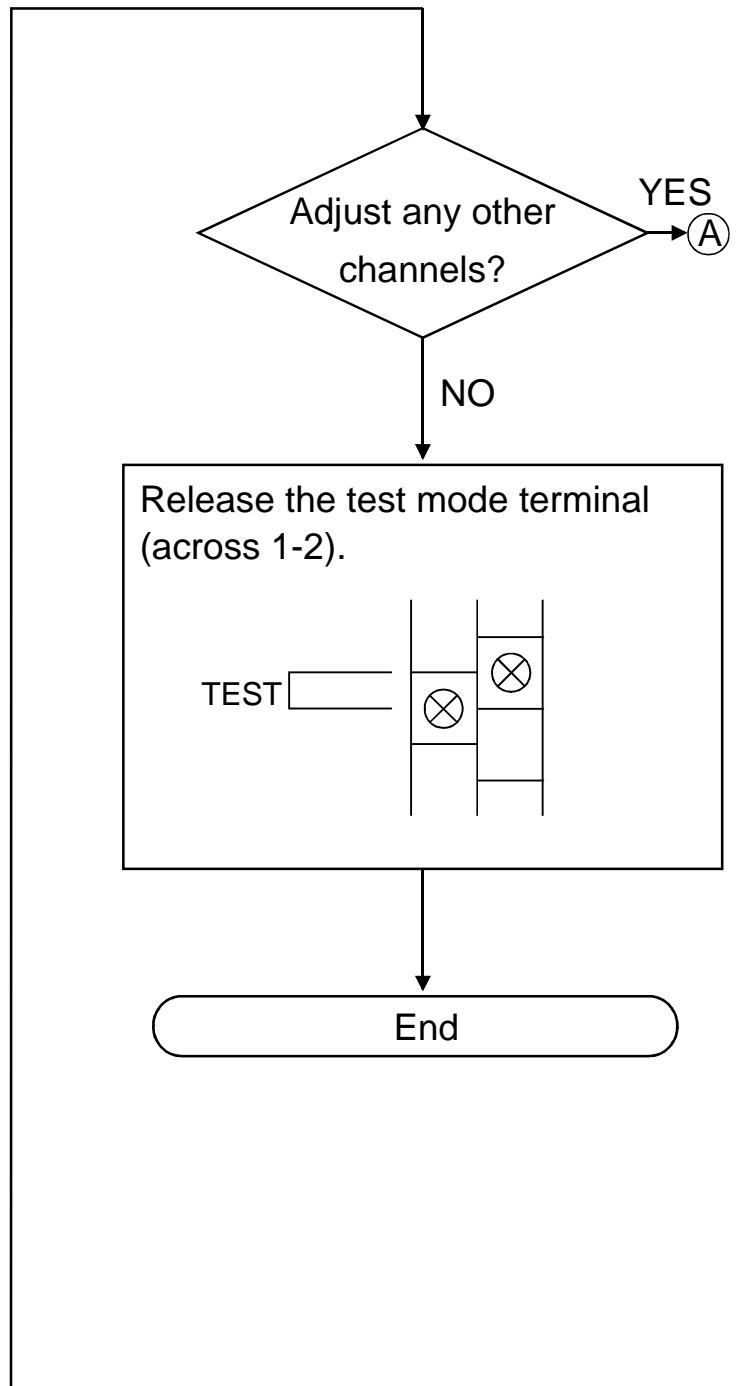
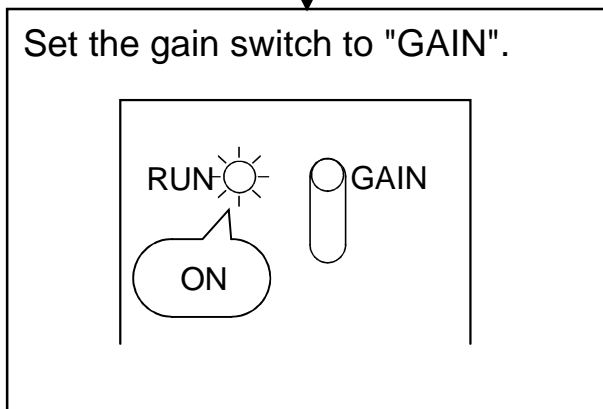
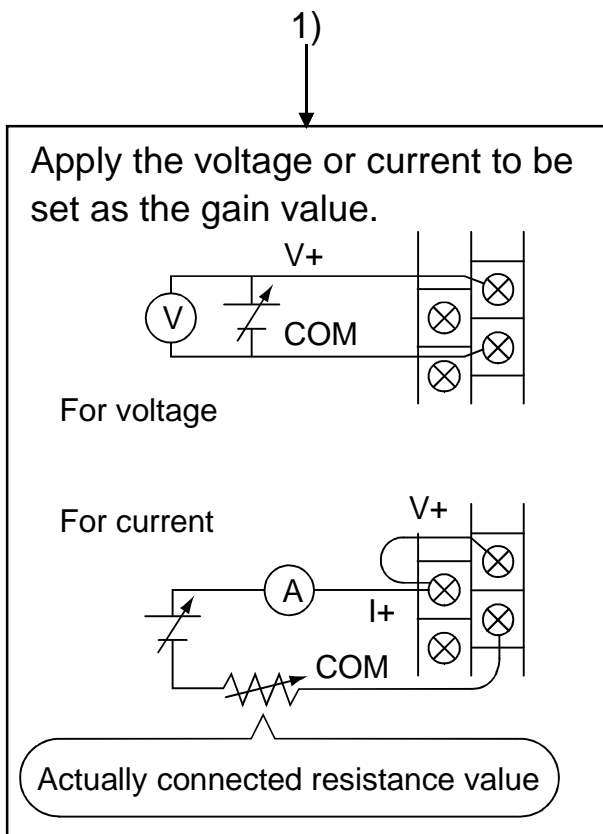

Remarks

The offset value and gain value have the following meanings.

- (1) The offset value is the analog input value (voltage or current) at which the digital output value is "0".
- (2) The gain value is the analog input value (voltage or current) at which the digital output value is the following:
 - (a) 2000 (1/4000 resolution)
 - (b) 4000 (1/8000 resolution)
 - (c) 6000 (1/12000 resolution)

4. Handling

4.1 Precautions for handling

- (1) The main body case and terminal block are made of resin, so do not drop them or apply strong impacts.
- (2) Do not remove the module PCB from the case. Doing so could lead to faults.
- (3) Make sure that foreign matter, such as wire scraps, does not enter from the top of the module during wiring. Remove any foreign matter that does enter.
- (4) Tighten the module installation screws and terminal screws within the following ranges.

Screw position	Tightening torque range
Module installation screw (M4 screw)	78 to 118N • cm
Terminal block terminal screw (M3.5 screw)	59 to 88N • cm
Terminal block installation screw (M4 screw)	78 to 118N • cm

5. Wiring

The precautions for wiring and an example of module connection are given in this section.

5.1 Precautions for wiring

External wiring that is not easily affected by noise is a prerequisite for using the A1S64AD functions to the fullest and creating a highly reliable system.

The precautions for external wiring are given below.

- (1) Use separate cables for the alternating current and A1S64AD external input signals to eliminate the effect of surge or inductance on the alternating current side.
- (2) Do not lay the wires or bundle the wires with the main circuit wires, high voltage wires or the load wire other than that from the PLC. Failure to observe this will increase the effect of noise, surge and inductance.
- (3) Ground the shield of a shielded wire or shielded cable to one point on the PLC side.

5.2 Example of module connection

An example for connecting the voltage input and current input is given below.

(1) For voltage input

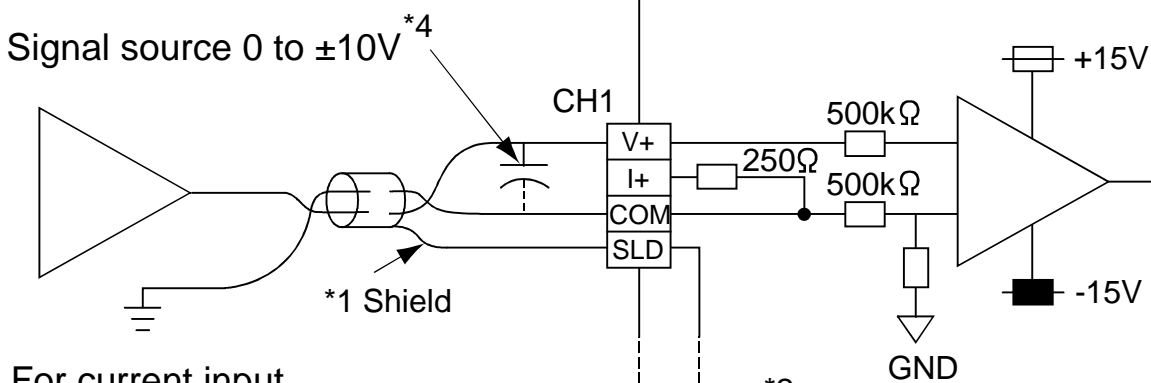

(2) For current input

Signal source 0 to $\pm 20mA$

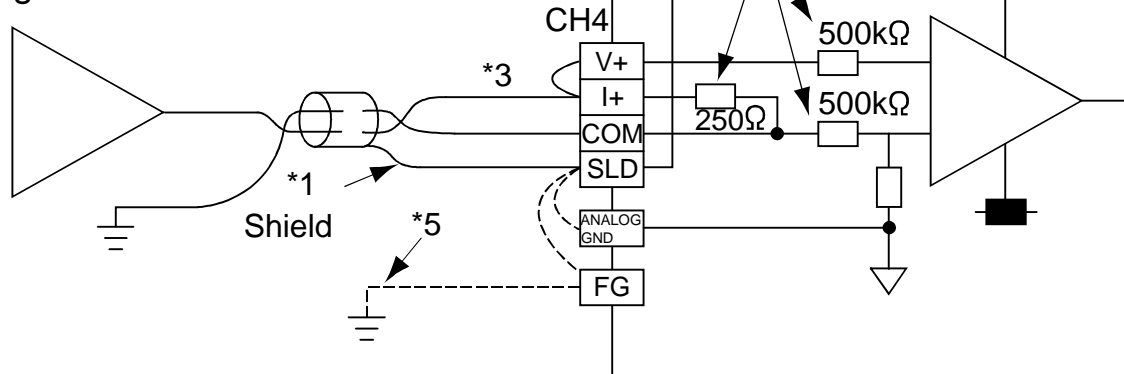

*1: Use a 2-core twisted shield wire.

*2: Indicates the A1S64AD input resistance.

*3: For the current input, always connect with the (V+) and (I+) terminals.

*4: If noise or ripple is generated in the external wiring, connect a 0.1 to 0.47 μF capacitor (approximate 25V or more withstand voltage) between the terminal V and COM.

*5: Ground if there are high levels of noise. There are cases when the power supply unit FG or this module FG should also be grounded.

When changing the grounding wiring (grounding or not grounding) after setting the offset value and gain value, set the offset value and gain value again.

6. Outline Dimension Drawing

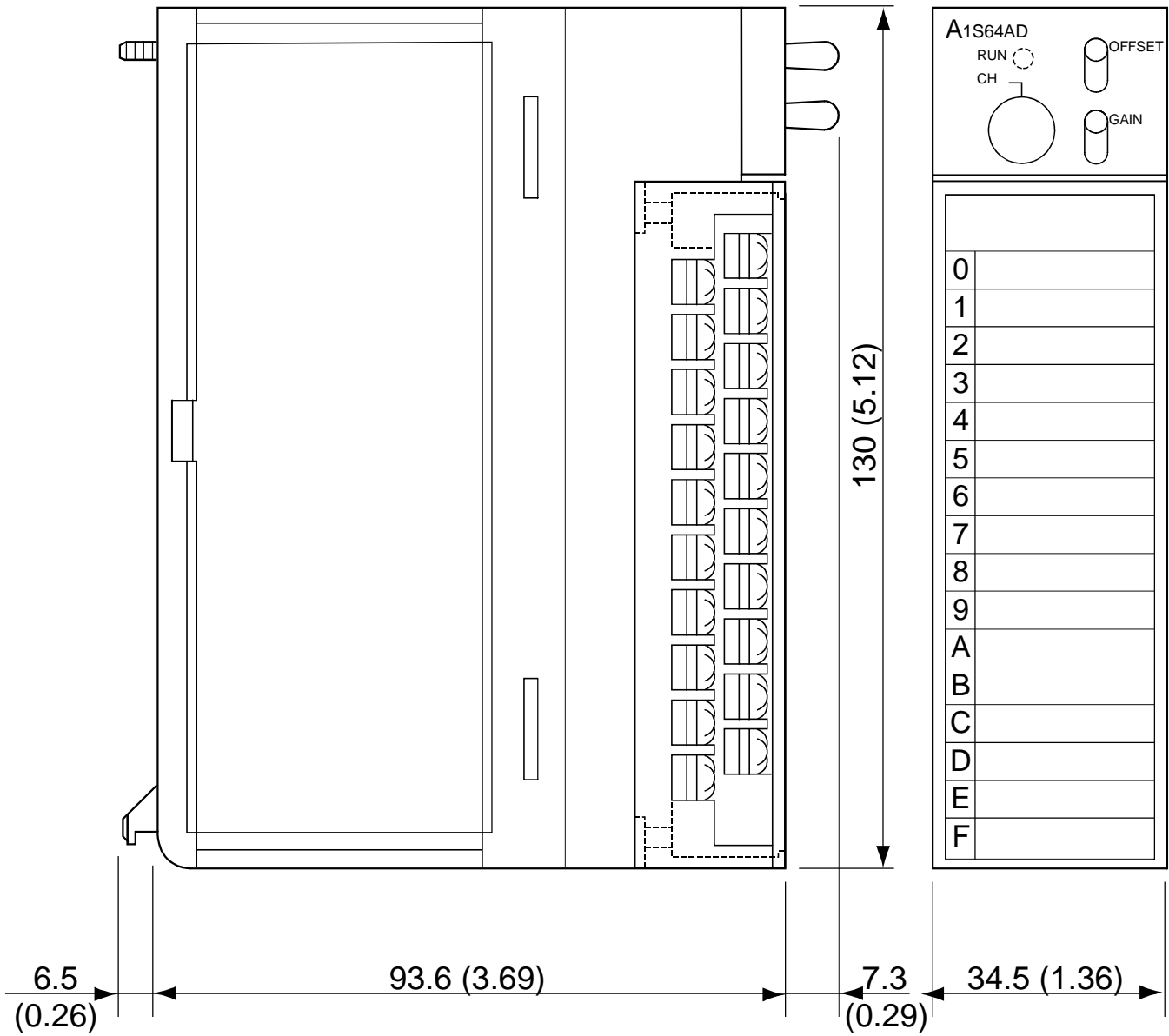

Unit:mm(in)

Warranty

Mitsubishi will not be held liable for damage caused by factors found not to be the cause of Mitsubishi; machine damage or lost profits caused by faults in the Mitsubishi products; damage, secondary damage, accident compensation caused by special factors unpredictable by Mitsubishi; damages to products other than Mitsubishi products; and to other duties.

For safe use

- This product has been manufactured as a general-purpose part for general industries, and has not been designed or manufactured to be incorporated in a device or system used in purposes related to human life.
- Before using the product for special purposes such as nuclear power, electric power, aerospace, medicine or passenger movement vehicles, consult with Mitsubishi.
- This product has been manufactured under strict quality control. However, when installing the product where major accidents or losses could occur if the product fails, install appropriate backup or failsafe functions in the system.

Country/Region	Sales office/Tel	Country/Region	Sales office/Tel
U.S.A	Mitsubishi Electric Automation Inc. 500 Corporate Woods Parkway Vernon Hills, IL 60061 Tel : +1-847-478-2100	China	Ryoden International Shanghai Ltd. 3F Block5 Building Automation Instrumentation Plaza 103 Cao Bao Rd. Shanghai 200233 China Tel : +86-21-6475-3228
Brazil	MELCO-TEC Rep. Com.e Assessoria Tecnica Ltda. Av. Rio Branco, 123-15 ,and S/1507, Rio de Janeiro, RJ CEP 20040-005, Brazil Tel : +55-21-221-8343	Taiwan	Setsuyo Enterprise Co., Ltd. 6F., No.105 Wu-Kung 3rd.RD, Wu-Ku Hsiang, Taipei Hsine, Taiwan Tel : +886-2-2299-2499
Germany	Mitsubishi Electric Europe B.V. German Branch Gothaer Strasse 8 D-40880 Ratingen, GERMANY Tel : +49-2102-486-0	Korea	HAN NEUNG TECHNO CO.,LTD. 1F Dong Seo Game Channel Bldg., 660-11, Deungchon-dong Kangsec-ku, Seoul, Korea Tel : +82-2-3660-9552
U.K	Mitsubishi Electric Europe B.V. UK Branch Travellers Lane, Hatfield, Herts., AL10 8XB,UK Tel : +44-1707-276100	Singapore	Mitsubishi Electric Asia Pte, Ltd. 307 ALEXANDRA ROAD #05-01/02, MITSUBISHI ELECTRIC BUILDING SINGAPORE 159943 Tel : +65-473-2480
Italy	Mitsubishi Electric Europe B.V. Italian Branch Centro Dir. Colleoni, Pal. Perseo - Ingr.2 Via Paracelso 12, 20041 Agrate B., Milano, Italy Tel:+39-039-60531	Thailand	F. A. Tech Co.,Ltd. 898/28,29,30 S.V.City Building,Office Tower 2,Floor 17-18 Rama 3 Road, Bangkokpong, Yannawa, Bangkok 10120 Tel : +66-2-682-6522
Spain	Mitsubishi Electric Europe B.V. Spanish Branch Carretera de Rubi 76-80 08190 - Sant Cugat del Valles, Barcelona, Spain Tel:+34-935-653135	Indonesia	P.T. Autoteknindo SUMBER MAKMUR Jl. Muara Karang Selatan Block A Utara No.1 Kav. No.11 Kawasan Industri/ Pergudangan Jakarta - Utara 14440 Tel : +62-21-663-0833
South Africa	Circuit Breaker Industries LTD. Private Bag 2016, Isando 1600, Johannesburg, South Africa Tel : +27-11-928-2000	India	Messung Systems Put,Ltd. Electronic Sadan NO:111 Unit No15, M.I.D.C BHOSARI,PUNE-411026 Tel : +91-20-7128927
Hong Kong	Ryoden Automation Ltd. 10th Floor, Manulife Tower, 169 Electric Road, North Point, HongKong Tel : +852-2887-8870	Australia	Mitsubishi Electric Australia Pty. Ltd. 348 Victoria Road, PostalBag, No 2, Rydalmere, N.S.W 2116, Australia Tel : +61-2-9684-7777

MITSUBISHI ELECTRIC CORPORATION

HEAD OFFICE : 1-8-12, OFFICE TOWER Z 14F HARUMI CHUO-KU 104-6212, JAPAN
NAGOYA WORKS : 1-14, YADA-MINAMI5, HIGASHI-KU, NAGOYA, JAPAN

When exported from Japan, this manual does not require application to the Ministry of Economy, Trade and Industry for service transaction permission.

Specifications subject to change without notice.
Printed in Japan on recycled paper.